



COUNCIL AGENDA **MONDAY, JANUARY 17, 2022 - 7:00 P.M.** **COMMUNITY CENTER – 503 ELM AVENUE**

- I. CALL TO ORDER AND ROLL CALL, 7:00 P.M.
- II. APPROVE/AMEND THE AGENDA
- III. APPROVAL OF THE JANUARY 3, 2022 REGULAR MEETING MINUTES
- IV. CITIZEN APPEARANCE:
 - A) Library – Regarding Proposed Expansion Project
 - B)
- V. Public Hearings:
 - A) Enter into a Loan Agreement and to Borrow Money in a Principal Amount Not to Exceed \$1,500,000
 - B)
- VI. LEGAL ITEMS:
 - A) Resolution No. 22-10 – Taking Additional Action on Proposal to Enter into a Loan Agreement, Authorizing the Use of a Term Sheet, and Setting Date for the Private Placement of a Taxable General Obligation Urban Renewal Land Acquisition Loan Agreement Project Note, Series 2022A
 - B) Resolution No. 22-11 – Awarding Contract for the City Hall Renovations Project
 - C) Resolution No. 22-12 – Authorizing the City of Story City to Submit an Application for Funding from the Federal Surface Transportation Block Grant Program (STBG) to the Central Iowa Regional Transportation Planning Alliance (CIRTPA) for the Partial for the Interstate 35 Bridge Approach Improvements Project
 - D)
- VII. ADMINISTRATIVE ITEMS:
 - A) Approve Pay Application No. 2 for the North Park Phase 3 Improvements Project
 - B) Approve Invoice for Fire Truck
 - C)

VIII. PERMITS:

A)

IX. MAYOR & CITY COUNCIL AGENDA ITEMS:

A) Reimbursement to Joel Weltha for City-Owned Farm Land

B) Schedule Special City Council Meeting for Monday, January 31st and Reschedule Regular City Council Meeting from February 7th to February 8th.

C)

X. APPROVAL OF BILLS AND CLAIMS

XI. MAYOR AND CITY COUNCIL COMMENTS REGARDING
NON-AGENDA ITEMS

XII. ADJOURNMENT

STORY CITY, IOWA

January 3, 2022

Mayor Jensen called the council meeting to order on Monday, January 3, 2022, at 7:00 pm at the Community Center.

Present: Mayor Jensen, Administrator Jackson, Attorney Fred Larson
Council Members: Ostrem, Phillips, Solberg, O'Connor, Sporleder
Absent: None

Also Present: Priscilla Johnson and three family members; Robert Endriss, Auditor, Denman & Co.

Motion by Ostrem, seconded by Sporleder, to approve the agenda.
Aye: Ostrem, Phillips, Solberg, O'Connor, Sporleder
Nay: None
Motion Carried.

Motion by Solberg, seconded by O'Connor, to approve the December 20, 2021 regular meeting minutes.
Aye: Ostrem, Phillips, Solberg, O'Connor, Sporleder
Nay: None
Motion Carried.

CITIZEN APPEARANCE

None.

PUBLIC HEARINGS

- A) Proposed Amendment to the Story City Consolidated Urban Renewal Area
Mayor Jensen opened the public hearing. Priscilla Johnson and three family members addressed the mayor and council with questions regarding the proposed amendment. Johnson stated that she did not object. There was general discussion. With no further comment, Mayor Jensen closed the public hearing.
- B) Proposed Amendment to the Fiscal Year 2021-22 Budget
Mayor Jensen opened the public hearing. With no public comment, Mayor Jensen closed the public hearing.

LEGAL ITEMS

A) **RESOLUTION NO. 22-1 – DESIGNATING OFFICIAL DEPOSITORIES FOR THE CITY**

Motion by Sporleder, seconded by Phillips, to approve Resolution No. 22- 1 – Designating Official Depositories For the City

Aye: Ostrem, Phillips, Solberg, O’Connor, Sporleder

Nay: None

Motion Carried.

B) **RESOLUTION NO. 22-2 – DESIGNATE DATE, TIME, AND PLACE FOR REGULAR COUNCIL MEETINGS**

Motion by Ostrem, seconded by O’Connor, to approve Resolution No. 22-2 – Designate Date, Time, and Place for Regular Council Meetings as first and third Mondays of each month, at 7 p.m. primarily in the City Hall Council Chambers, with the alternate location being the Community Center.

Aye: Ostrem, Phillips, Solberg, O’Connor, and Sporleder

Nay: None

Motion Carried.

C) **RESOLUTION NO. 22-3 – DESIGNATE OFFICIAL NEWSPAPER**

Motion by Phillips, seconded by Ostrem, to approve Resolution No. 22-3 – Designate Official Newspaper Story City Herald and the Tribune

Aye: Ostrem, Phillips, Solberg, O’Connor, and Sporleder

Nay: None

Motion Carried.

D) **RESOLUTION NO. 22-4 – APPOINT CITY ATTORNEY**

Motion by Sporleder, seconded by Solberg, to approve Resolution No. 22-4 – Appointment of Fred Larson as City Attorney

Aye: Ostrem, Phillips, Solberg, O’Connor, and Sporleder

Nay: None

Motion Carried.

E) **RESOLUTION NO. 22-5 – APPOINTMENT OF CITY CLERK & TREASURER**

Motion by O’Connor, seconded by Sporleder, to approve Resolution No. 22-5 – Appointment of Heather Slifka as City Clerk & Treasurer

Aye: Ostrem, Phillips, Solberg, O’Connor, and Sporleder

Nay: None

Motion Carried.

F) **RESOLUTION NO. 22-6 – APPOINTMENT OF BUILDING INSPECTORS**

Motion by Solberg, seconded by Ostrem, to approve Resolution No. 22-6 –

Appointment of Safe Building as the Building Inspectors

Aye: Ostrem, Phillips, Solberg, O’Connor, and Sporleder

Nay: None

Motion Carried.

G) **RESOLUTION NO. 22-7 – TO DECLARE NECESSITY AND ESTABLISH AN URBAN RENEWAL AREA, PURSUANT TO SECTION 403.4 OF THE CODE OF IOWA AND APPROVE URBAN RENEWAL PLAN AMENDMENT FOR THE STORY CITY CONSOLIDATED URBAN RENEWAL AREA**

Planning and Zoning Commission reviewed the Urban Renewal Plan Amendment and commented that it conforms and is Consistent with the Comprehensive Plan and Recommends Approval.

Motion by O’Connor, seconded by Phillips, to approve Resolution No. 22-7 – To Declare Necessity and Establish an Urban Renewal Area, Pursuant to Section 403.4 of the Code of Iowa and Approve Urban Renewal Plan Amendment for the Story City Consolidated Urban Renewal Area

Aye: Ostrem, Phillips, Solberg, O’Connor, and Sporleder

Nay: None

Motion Carried.

H) **RESOLUTION NO. 22-8 – AMENDING THE CURRENT BUDGET FOR FISCAL YEAR ENDING JUNE 2022**

Motion by Phillips, seconded by Sporleder, to approve

Resolution No. 22-8 – Amending the Current Budget For Fiscal Year

Ending June 2022

I) **ORDINANCE NO. 322 – ESTABLISHING VOTING PRECINCTS IN THE CITY OF STORY CITY, IOWA IN RESPONSE TO THE FEDERAL DECENNIAL CENSUS IN ACCORDANCE WITH CHAPTER 49, CODE OF IOWA BY AMENDING THE CODE OF ORDINANCES CHAPTER 6, SECTION 6.07 AND RE-ADOPTING SAID CHAPTER AND SECTION AS REVISED AND ESTABLISHING EFFECTIVE DATE, WAIVE TWO READINGS AND PROCEED TO FINAL READING**

Council Member Sporleder Introduced Ordinance 322, an Ordinance Establishing Voting Precincts In The City Of Story City, Iowa In Response To The Federal Decennial Census In Accordance With Chapter 49, *Code Of Iowa* By Amending The Code Of Ordinances Chapter 6, Section 6.07 And Re-Adopting Said Chapter And Section As Revised And Establishing Effective Date, Waive Two Readings And Proceed To Final Reading

Motion by Phillips, seconded by Sporleder, to adopt Ordinance 322.

Aye: Ostrem, Phillips, Solberg, O’Connor, and Sporleder

Nay: None

Motion Carried.

Motion by O'Connor, seconded by Ostrem, to suspend the statutory rule requiring an ordinance to be considered and voted on for passage at two Council meetings prior to the meeting at which it is finally passed.

Aye: Ostrem, Phillips, Solberg, O'Connor, and Sporleder

Nay: None

Motion Carried.

Motion by Solberg, seconded by Sporleder, to approve Ordinance 322- Establishing Voting Precincts In The City Of Story City, Iowa In Response To The Federal Decennial Census In Accordance With Chapter 49, *Code Of Iowa* By Amending The Code Of Ordinances Chapter 6, Section 6.07 And Re-Adopting Said Chapter And Section As Revised And Establishing Effective Date, Now be put into its final consideration and adoption.

Aye: Ostrem, Phillips, Solberg, O'Connor, and Sporleder

Nay: None

Motion Carried.

J) **ORDINANCE NO. 323 – PROVIDING FOR THE DIVISION OF TAXES LEVIED ON TAXABLE PROPERTY IN THE JANUARY, 2022 ADDITION TO THE STORY CITY CONSOLIDATED URBAN RENEWAL AREA, PURSUANT TO SECTION 403.19 OF THE CODE OF IOWA, WAIVE TWO READINGS AND PROCEED TO FINAL READING**

Council Member Solberg introduced Ordinance No. 323 – Providing for the Division of Taxes Levied on Taxable Property in the January, 2022 Addition to the Story City Consolidated Urban Renewal Area, Pursuant to Section 403.19 of the Code of Iowa, Waive Two Readings and Proceed to Final Reading

Motion by Phillips, seconded by Sporleder, to adopt Ordinance 323.

Aye: Ostrem, Phillips, Solberg, O'Connor, and Sporleder

Nay: None

Motion Carried.

Motion by Ostrem, seconded by Solberg, to suspend the statutory rule requiring an ordinance to be considered and voted on for passage at two Council meetings prior to the meeting at which it is finally passed.

Aye: Ostrem, Phillips, Solberg, O'Connor, and Sporleder

Nay: None

Motion Carried.

Motion by Ostrem, seconded by Sporleder, to approve Ordinance 323- Providing for the Division of Taxes Levied on Taxable Property in the January, 2022 Addition to the Story City Consolidated Urban Renewal Area, Pursuant to Section 403.19 of the Code of Iowa, now be put into its Final Consideration and Adoption

Aye: Ostrem, Phillips, Solberg, O'Connor, and Sporleder

Nay: None

Motion Carried.

K) **RESOLUTION NO. 22-9 – SETTING THE DATE FOR PUBLIC HEARING ON PROPOSAL TO ENTER INTO A TAXABLE GENERAL OBLIGATION URBAN RENEWAL LAND ACQUISITION LOAN AGREEMENT AND TO BORROW MONEY THEREUNDER IN AN AGGREGATE PRINCIPAL AMOUNT NOT TO EXCEED \$1,500,000**

Motion by Ostrem, seconded by Phillips, to approve Resolution No. 22-9 – Setting the Date of January 17th, 2022 at 7:00 p.m., for Public Hearing on Proposal to Enter into a Taxable General Obligation Urban Renewal Land Acquisition Loan Agreement and to Borrow Money thereunder in an Aggregate Principal Amount Not to Exceed \$1,500,000

Aye: Ostrem, Phillips, Solberg, O’Connor, and Sporleder

Nay: None

Motion Carried.

ADMINISTRATIVE ITEMS

- A) Review and Accept Audit for Fiscal Year Ending June 30, 2021
Robert Endriss, Auditor, Denman & Co. presented a summary of the FY 20/21 Audit. There were no significant findings or demerits. Mayor and Council had general discussion.

Motion by Sporleder, seconded by O’Connor, to Accept Audit for Fiscal Year Ending June 30, 2021

Aye: Ostrem, Phillips, Solberg, O’Connor, and Sporleder

Nay: None

Motion Carried.

- B) Approve Memorandum of Agreement with Story County with Regards to Voting Precincts

The County has changed the voting precincts as presented to council.

Motion by Solberg, seconded by Ostrem, to approve the Memorandum of Agreement with Story County with Regards to Voting Precincts

Aye: Ostrem, Phillips, Solberg, O’Connor, and Sporleder

Nay: None

Motion Carried.

PERMITS

None.

MAYOR & CITY COUNCIL AGENDA ITEMS

- A) Appointment of Mark Jackson as City Representative to CIRTPA Policy and Technical Committees

Motion by O’Connor, seconded by Sporleder, to approve Appointment of Mark Jackson as City Representative to CIRTPA Policy and Technical Committees

APPROVAL OF BILLS AND CLAIMS

Motion by Sporlder, seconded by O'Connor, to approve Payment of Bills and Claims.

Aye: Ostrem, Phillips, Solberg, O'Connor, and Sporlder

Nay: None

Motion Carried.

MAYOR AND CITY COUNCIL COMMENTS REGARDING NON-AGENDA ITEMS

- CM O'Connor requested an update on the slip lining project along Grove Street
 - Administrator Jackson stated that the project went well overall, though the contractor is working thru an insurance claim on a property that had sewer in the basement

- CM Solberg presented a review of the recent Library Board meeting
- CM Phillips stated that Business After Hours is at Reliance State Bank on the 6th of Jan.
- CM Ostrem asked about whether the city purchases handicap signs for the golf course
 - Administrator Jackson stated that the city would purchase them, as the golf course is owned by the city
- Administrator Jackson stated that the council will be going over the budget at the next meeting.

There being no further business before council, the meeting adjourned at 7:55 p.m.

ATTEST:

Heather Slifka, City Clerk

Mike Jensen, Mayor

RESOLUTION NO. 22-10

Resolution taking additional action on proposal to enter into a Loan Agreement, authorizing the use of a Term Sheet, and setting date for the private placement of a Taxable General Obligation Urban Renewal Land Acquisition Loan Agreement Project Note, Series 2022A

WHEREAS, the City of Story City (the “City”), in Story County, State of Iowa heretofore proposed to enter into a Taxable General Obligation Urban Renewal Land Acquisition Loan Agreement (the “Loan Agreement”), pursuant to the provisions of Section 384.24A and 384.24.3(q) of the Code of Iowa, and to borrow money thereunder in a principal amount not to exceed \$1,500,000 for the purpose of paying certain costs, to that extent, of undertaking the Land Acquisition Project, an urban renewal project in the Story City Consolidated Urban Renewal Area, authorized by action of the City Council on January 3, 2022; and in lieu of calling an election upon such proposal, has published notice of the proposed action, including notice of the right to petition for an election, and has held a hearing thereon, and as of January 17, 2022, no petition had been filed with the City asking that the question of entering into the Loan Agreement be submitted to the registered voters of the City; and

WHEREAS, pursuant to the provisions of Section 76.13 of the Code of Iowa, the City has authority to issue anticipation project notes in anticipation of the receipt of the proceeds from the Loan Agreement (the “Loan Proceeds”); and

WHEREAS, a certain term sheet (the “Term Sheet”) has been prepared to facilitate the private placement of Taxable General Obligation Urban Renewal Land Acquisition Loan Agreement Anticipation Project Note, Series 2022A (the “Project Note”) in anticipation of the receipt of and payable from the Loan Proceeds, and it is now necessary to make provision for the approval of the Term Sheet and to authorize its use by D.A. Davidson & Co., (the “Placement Agent”); and

WHEREAS, it is now necessary to set the date for the receipt of proposals for the private placement of the Project Note and to authorize the Placement Agent to negotiate such proposals for private placement;

NOW, THEREFORE, Be It Resolved by the City Council of the City of Story City, Iowa, as follows:

Section 1. The City Council hereby determines to enter into the Loan Agreement in the future and orders that general obligation bonds or notes be issued at such time, in evidence thereof. The City Council further declares that this resolution constitutes the “additional action” required by Section 384.24A of the Code of Iowa.

Section 2. The City Clerk is hereby authorized to take such action as shall be deemed necessary and appropriate, with the assistance of the Placement Agent, to prepare and use the Term Sheet describing the Project Note and providing for the terms and conditions of their

placement and to receive proposals for the private placement of the Project Note, and all action heretofore taken in this regard is hereby ratified and approved.

Section 3. The City Clerk is hereby authorized to take such action as shall be deemed necessary and appropriate, with assistance from Dorsey & Whitney, LLP and the Placement Agent, to facilitate January 31, 2022 as the date for the receipt of proposals for the placement of the Project Note.

Section 4. All resolutions or parts thereof in conflict herewith are hereby repealed to the extent of such conflict.

Section 5. This resolution shall be in full force and effect immediately upon its adoption and approval, as provided by law.

Passed and approved January 17, 2022.

Mike Jensen, Mayor

Attest:

Heather Slifka, City Clerk

....

The meeting was adjourned.

Mike Jensen, Mayor

Attest:

Heather Slifka, City Clerk

CITY of STORY CITY, IOWA



**Taxable G.O. Annual Appropriation Urban Renewal
Loan Agreement Anticipation Project Note, Series 2022A**

January 2022



D | A | DAVIDSON
D.A. Davidson & Co. member SIPC

Nathan Summers
Vice President
515.471.2722
nsummers@dadco.com

Proposed Terms



-
- Principal amount of approximately \$1,385,000 (subject to change) (the “Bonds”).
 - Tax status of interest:
 - ✓ Taxable with regard to Federal and State taxes
 - Principal paid March 1, 2023, with first interest payment December 1, 2022.
 - Loan will be non-rated.
 - ✓ Open to rating if pricing benefit outweighs cost of rating.
 - Average life of approximately 1.008 years.
 - Par call any time.
 - Dated Date: Date of Delivery (expected on or about February 28, 2022)

Preliminary Timeline



-
- Late December or Early January: Information distributed to potential lenders
 - **By 1:00 PM (Central) January 26: bank proposals due to D.A. Davidson**
 - ✓ Council will hold a meeting the evening of January 31 for full approval by City Council
 - **January 31: Selected bank proposal/term sheet approved**
 - ✓ Council will hold a meeting the evening of January 31 to formally accept a purchaser's proposal
 - **February 14: Resolution authorizing issuance**
 - **February 28: Closing**

Purpose of Financing and Future Debt Plans



- **Purpose:** The City anticipates using the bonds for undertaking a Land Acquisition Project, an urban renewal project in the Story City Consolidated Urban Renewal Area, authorized by action of the City Council on January 3, 2022.

Security for the Proposed Bonds



- Pursuant to the Resolution and the Act, the Bonds and the interest thereon are general obligations of the Issuer, and all taxable property within the boundaries of the Issuer is subject to the levy of taxes to pay the principal of and interest on the Bonds without constitutional or statutory limitation as to rate or amount. See “APPENDIX A – INFORMATION ABOUT THE ISSUER.”
- Section 76.2 of the Code of Iowa, 2021, as amended (the “Iowa Code”) provides that when an Iowa political subdivision issues general obligation bonds, the governing authority of such political subdivision shall, by resolution adopted before issuing the bonds, provide for the assessment of an annual levy upon all the taxable property in the political subdivision sufficient to pay the interest and principal of the bonds. A certified copy of this resolution shall be filed with the County Auditor in which the Issuer is located, giving rise to a duty of the County Auditor to annually enter this levy for collection from the taxable property within the boundaries of the Issuer, until funds are realized to pay the bonds in full.
- For the purpose of providing for the levy and collection of a direct annual tax sufficient to pay the principal of and interest on the Bonds as the same become due, the Resolution provides for the levy of a tax sufficient for that purpose on all the taxable property in the Issuer in each of the years while the Bonds are outstanding. The Issuer shall file a certified copy of the Resolution with the County Auditor, pursuant to which the County Auditor is instructed to enter for collection and assess the tax authorized. When annually entering such taxes for collection, the County Auditor shall include the same as a part of the tax levy for Debt Service Fund purposes of the Issuer and when collected, the proceeds of the taxes shall be converted into the Debt Service Fund of the Issuer and set aside therein as a special account to be used solely and only for the payment of the principal of and interest on the Bonds and for no other purpose whatsoever.
- Pursuant to the provisions of Section 76.4 of the Iowa Code, each year while the Bonds remain outstanding and unpaid, any funds of the Issuer which may lawfully be applied for such purpose, may be appropriated, budgeted and, if received, used for the payment of the principal of and interest on the Bonds as the same become due, and if so appropriated, the taxes for any given fiscal year as provided for in the Resolution, shall be reduced by the amount of such alternate funds as have been appropriated for said purpose and evidenced in the Issuer’s budget.

Recent Rating Actions



- The City's General Obligation debt is currently rated "A+ Stable" by Standard and Poor's.
- However, the Bonds are not anticipated to carry a rating.
- Copies of rating reports are available upon request, and are also available under the District's EMMA filings.

Proposed Structure



Period Ending	Principal
12/01/2022	-
03/01/2023	1,385,000
	1,385,000

General Information – Receipts & Disbursements



SCHEDULE OF RECEIPTS AND DISBURSEMENTS (General Fund)

<u>Fiscal Year</u>	<u>Beginning Balance</u>	<u>Receipts</u>	<u>Disbursements</u>	<u>Ending Balance</u>
2019/20	\$1,184,339	\$2,286,935	\$2,248,408	\$1,222,866
2018/19	\$1,031,488*	\$2,154,029	\$2,001,178	\$1,184,339
2017/18	\$869,152	\$1,923,277	\$1,748,435	\$1,043,994
2016/17	\$712,694	\$1,824,862	\$1,668,404	\$869,152
2015/16	\$656,127	\$1,736,967	\$1,680,400	\$712,694

*The City restated beginning fund balances in order to correct errors in fund classifications relating to hotel/motel tax revenue.

Source: The City.

SCHEDULE OF RECEIPTS AND DISBURSEMENTS (All Funds)

<u>Fiscal Year</u>	<u>Beginning Balance</u>	<u>Receipts</u>	<u>Disbursements</u>	<u>Ending Balance</u>
2019/20	\$4,942,117	\$5,973,782	\$6,717,546	\$4,198,353
2018/19	\$2,686,513	\$6,785,543	\$4,529,939	\$4,942,117
2017/18	\$4,793,133*	\$4,170,189	\$6,276,809	\$2,686,513
2016/17	\$5,088,582	\$8,067,389	\$7,622,945	\$5,533,026
2015/16	\$2,340,019	\$7,972,064	\$5,223,501	\$5,088,582

*The City restated beginning fund balances in order to correct errors in fund classifications and to include discretely presented component units.

Source: The City.

General Information – Top Taxpayers



LARGER TAXPAYERS BY VALUATION

Set forth in the following table are the persons or entities that represent larger taxpayers within the boundaries of the City, as provided by the Story County Auditor's office. No independent investigation has been made of and no representation is made herein as to the financial condition of any of the taxpayers listed below or that such taxpayers will continue to maintain their status as major taxpayers in the City. With the exception of the electric and natural gas providers (which is subject to an excise tax in accordance with Iowa Code chapter 437A), the City's tax levy is applicable to all of the properties included in the table, and thus taxes expected to be received by the City from such taxpayers will be in proportion to the assessed valuations of the properties. The total tax bill for each of the properties is dependent upon the tax levies of the other taxing entities which overlap the properties.

Top Ten Taxpayers by 2020 Taxable Value (for 2021/22 collection)⁽¹⁾:

<u>Taxpayer</u>	<u>11/2020 Taxable Valuation</u>
Broadstone WS Iowa LLC	\$16,467,480
American Packaging Corp	7,451,910
Generation Repair & Service LLC	6,862,500
Ramki & Sumathy Group Holdings LLC	3,545,820
TNL Development LLC	2,857,322
Vanhouweling Property LLC	2,117,250
Prairie Drive Apartments LLC	2,064,082
M B S Genetics LLC	2,036,070
H A Corporation	1,957,950
Key Cooperative	<u>1,859,310</u>
Total:	\$47,219,694

Larger Taxpayers as % of Total 2020 Taxable Valuation: 24.46%

Source: Story County

(1) Kwik Trip, Inc. has developed a property with 11/2021 valuation (for 2022-23 collection) estimated at \$3,164,800. This valuation has yet to be certified by the County, which typically occurs on or about July 1, 2022. Source: Story County and the City.

General Information – Debt Limit Calculation



DEBT LIMIT CALCULATION

The amount of general obligation debt a political subdivision of the State of Iowa can incur is controlled by constitutional debt limit which is an amount equal to 5% of the value of taxable property within its limits as ascertained by the last state and county tax lists. The Issuer's debt limit, based upon 2020 property valuations, is illustrated below:

Total Market Valuation	\$302,394,276
Less: Military Exemption	(287,060)
100% Actual Valuation	<u>\$302,107,216</u>
	x 5%
Legal Debt Limit	<u>\$15,105,361</u>
Debt Applicable to limit:	
Total General Obligation Debt Subject to Legal Debt Limit	<u>\$10,374,751</u>
Legal Debt Limit Available	\$4,730,610
Percentage of Debt Limit Available	31.32%

* Preliminary, subject to change

Additionally, the city will be paying off approximately \$814,278 in principal payment at the end of FY2022.

The calculation above is based off of the entire Series 2022A Loan amount, but once converted to a long-term bond, the Annual Appropriation pledge will cause only annual principal payments to be used in the debt limit calculation, thereby lowering the amount of the Loan which will count against the debt limit going forward.

General Information – Overlapping and Underlying Debt



Overlapping Debt:

Story County

2020 100% Valuation	\$8,759,283,076
2020 Taxable Valuation	\$5,618,865,691
General Obligation Bonded Debt	\$5,223,608
Percent Allocable to City	3.53%
Amount Allocable to City	\$184,372
City's share of Debt per Capita	\$53.74

Roland-Story Community School District

2020 100% Valuation	\$608,102,075
2020 Taxable Valuation	\$396,167,013
General Obligation Bonded Debt	\$6,940,000
Percent Allocable to City	50.06%
Amount Allocable to City	\$3,474,188.99
City's share of Debt per Capita	\$1,012.59

DMACC

2020 100% Valuation	\$87,749,304,274
2020 Taxable Valuation	\$56,678,598,966
Bonded Debt:	
General Obligation School Bonds/Notes	\$45,425,000
General Obligation Certificates, Industrial New Jobs Training Certificates	\$2,135,000
Total General Obligation Bonded Debt	\$97,560,000 ¹
Percent Allocable to City	0.35%
Amount Allocable to City (excludes New Jobs Training Certificates)	\$158,945
City's share of Debt per Capita (excludes New Jobs Training Certificates)	\$46.33

¹ The Certificates were issued to finance projects which provide education and training of workers for new or expanding industry in the Merged Area. While secured by an annual levy of a standby tax upon all taxable property in the Merged Area, the debt service is payable from revenues of the respective projects and the standby tax will be collected only in the event such revenues are insufficient.

² Preliminary, subject to change.

General Information – Valuation Trend



VALUATION TREND

Valuation Year	Payable Fiscal Year	100% Actual Valuation	Taxable Valuation (With Rollback)	Taxable TIF Increment Valuation	Total Taxable Valuation
2020	2021/22	\$302,107,216	\$166,766,471	\$31,556,162	\$198,322,633
2019	2020/21	\$298,123,157	\$162,368,300	\$30,711,313	\$193,079,613
2018	2019/20	\$272,838,782	\$149,162,979	\$30,484,174	\$179,647,153
2017	2018/19	\$268,669,775	\$146,604,892	\$27,940,151	\$174,545,043
2016	2017/18	\$252,030,777	\$135,382,814	\$32,442,062	\$167,824,876

The 100% actual valuations, before rollback and after reduction of military exemption, include gas, land and buildings, TIF increment, and gas and electric utilities and are used for calculating debt capacity. The taxable valuations, with the rollback and after the reduction of military exemption, include gas and electric utilities, exclude gas, land and buildings, and exclude taxable TIF increment value, which is shown separately. Iowa cities certify operating levies against taxable value excluding TIF increment. However, debt service levies are certified against taxable value including TIF increment.

Source: Iowa Department of Management.

General Information – Tax Collection History



TAX COLLECTION TREND (All Funds)

Valuation Year	Collection Year	Amount Levied	Amount Collected*	Percent Collected
2020	2021/22	\$1,747,871	<i>In Process of Collection</i>	
2019	2020/21	\$1,677,455	\$1,701,611	101.44%
2018	2019/20	\$1,521,242	\$1,555,305	102.24%
2017	2018/19	\$1,565,118	\$1,607,126	102.68%
2016	2017/18	\$1,488,948	\$1,507,562	101.25%

* Includes delinquent taxes, if any.

Source: The City.

General Information – Unemployment Statistics



UNEMPLOYMENT STATISTICS

	<u>2020</u>	<u>2019</u>	<u>2018</u>	<u>2017</u>	<u>2016</u>	<u>2015</u>
County of Story	3.6%	1.8%	1.6%	2.0%	2.3%	2.5%
State of Iowa	5.3%	2.8%	2.6%	3.1%	3.6%	3.7%

Source. Iowa Workforce Development, not seasonally adjusted

RESOLUTION NO. 22-11

Resolution awarding contract for the City Hall Renovations Project

WHEREAS, pursuant to notice duly posted in the manner and form prescribed by resolution of the City Council of the City of Story City, Iowa, and as required by law, bids and proposals were received by this Council for the City Hall Renovations Project (the "Project"); and

WHEREAS, all of the said bids and proposals have been carefully considered, and it is necessary and advisable that provision be made for the award of the contract for the Project;

NOW, THEREFORE, Be It Resolved by the City Council of the City of Story City, Iowa, as follows:

Section 1. The bid for the Project submitted by the following contractor is fully responsive to the plans and specifications for the Project, is heretofore approved by the City Council, and is the lowest responsible bid received, such bid being as follows:

<u>Name and Address of Contractor</u>	<u>Amount of Bid</u>
<u>R. H. Grabau Construction</u>	<u>\$535,000.00</u>
<u>871 P Avenue</u>	
<u>Boone, IA</u>	

Section 2. The contract for the Project is hereby awarded to such contractor at the total estimated cost set out above, the final settlement to be made on the basis of the unit prices therein set out and the actual final quantities of each class of materials furnished, the said contract to be subject to the terms of the aforementioned resolution, the notice of hearing and letting, the plans and specifications and the terms of the bidder's written proposal.

Section 3. The Mayor and City Clerk are hereby authorized and ordered to enter into a written contract with said contractor for the Project, said contract not to be binding until approved by resolution of this City Council.

Section 4. The amount of the contractor's performance and/or payment bonds is hereby fixed and determined to be 100% of the amount of the contract.

Section 5. All resolutions or parts of resolutions in conflict herewith are hereby repealed to the extent of such conflict.

Passed and approved January 17, 2022.

Mike Jensen, Mayor

Attest:

Heather Slifka, City Clerk

CITY OF STORY CITY

504 Broad Street
Story City, IA 50248
515.733.2121

www.cityofstorycity.org

1913 Herschell-Spillman Carousel

To: The Honorable Mayor & City Council
From: Mark A. Jackson, City Administrator *MAJ*
Re: Resolution No. 22-12 – Application for CIRTPA Grant
for Interstate 35 Bridge Approach Improvements Project
Date: January 17, 2022

Presented for Mayor and City Council consideration is Resolution No. 22-12 for the purpose of authorizing a grant application to the Central Iowa Regional Transportation Planning Alliance (CIRTPA) for grant funding for the resurfacing of the approaches to the Interstate 35 bridge.

The Small Community Fund is a competitive grant through CIRTPA that has approximately \$240,000 in funding for roadway projects. Grant applications are due by February 11th.

At its October 4, 2021, meeting, the City Council approved entering into an agreement with the Iowa Department of Transportation for resurfacing of the bridge approaches as part of an IDOT project. The estimated cost of the project is \$158,500 and the grant request is in the amount of \$126,800.

The following resolution was offered by Councilperson _____, who moved its adoption.

RESOLUTION NO. 22-12

RESOLUTION AUTHORIZING THE CITY OF STORY CITY TO SUBMIT AN APPLICATION FOR FUNDING FROM THE FEDERAL SURFACE TRANSPORTATION BLOCK GRANT PROGRAM (STBG) TO THE CENTRAL IOWA REGIONAL TRANSPORTATION PLANNING ALLIANCE (CIRTPA) FOR THE PARTIAL FUNDING FOR THE INTERSTATE 35 BRIDGE APPROACH IMPROVEMENTS PROJECT, PROJECT

WHEREAS, the City of Story City is located in the Central Iowa Regional Transportation Planning Alliance Planning Area, and

WHEREAS, the Federal Surface Transportation Block Grant Program provides funding for local jurisdictions for the construction of eligible projects, and

WHEREAS, the program is administered by the Central Iowa Regional Transportation Planning Alliance which prioritizes and ranks all project applications.

NOW, THEREFORE, BE IT RESOLVED by the City Council of the City of Story City, Iowa, as follows:

Section 1. The City of Story City supports and approved the application for Federal Surface Transportation Program Funding for the Interstate 35 Bridge Approach Improvements Project.

Section 2. The City Council of the City of Story City hereby commits matching monies as required by the Federal Surface Transportation Program funding.

Section 3. The City of Story City hereby commits to accepting and maintaining these improvements for a minimum of twenty (20) years following the completion of the project.

Section 4. All resolutions or parts of resolutions in conflict herewith be and the same repealed, to the extent of such conflict.

BE IT FURTHER RESOLVED that the City Administrator of the City of Story City is hereby authorized to approve and execute the application on behalf of the City Council of Story City, Iowa.

The motion was seconded by Councilperson _____, and, upon roll call, was carried by an aye and nay vote, as follows:

AYE: _____

NAY: _____

ABSENT: _____

WHEREPON, the Mayor declared the Resolution duly adopted this 17th day of January, 2022.

Mike Jensen, Mayor

ATTEST: _____
Heather Slifka, City Clerk



Runout Filler Quantities:

Location	lt.	sq. yds.	Milling
6584+00	16	86	9
6584+00	14	148	14
6584+00	26	147	15
6594+00	18	102	9
Totals	87	483	47

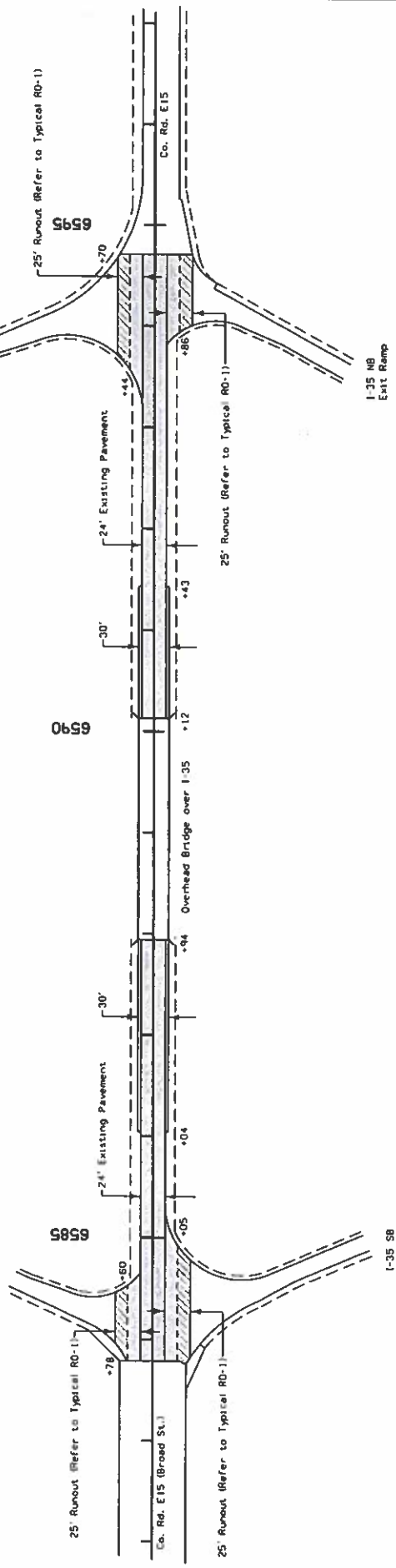

I-35 and Co. Rd. E15 Interchange (Story City)

Co. Rd. E15 (Division 2)
HMA Resurfacing Details



- Proposed HMA Resurfacing (3" Depth)
- Pavement Scarification (Drilling)

2022-8-030_StoryCity

ENGLISH | TONY DOT

DESIGN TEAM | Tony Gustafson | Gary Mackey

STORY-HAMILTON COUNTY

PROJECT NUMBER | IMX-35-5(97)121--02-85

SHEET NUMBER | K.7

Estimated Cost:**Roadway Items:**

HMA Intermediate Course – 283 Tons	\$	17,000
HMA Surface Course – 283 Tons	\$	21,000
HMA Binder – 34 Tons	\$	19,000
Full-Depth Patches – 320 SY	\$	50,000
Patches (by Count) – 40 EA	\$	7,000
Pavement Markings – 104 STA	\$	1,000
Milling – 3,470 SY	\$	21,000
Traffic Control	\$	3,000
Mobilization	\$	5,000
<u>Contingency (10%)</u>	<u>\$</u>	<u>14,500</u>
Estimated Total (100% CITY)	\$	158,500

APPLICATION FOR PARTIAL PAYMENT OF CONTRACT



Project Title: Story City North Park Phase 3 Improvements
Contractor: Caliber Concete, LLC
Address: 309 Audubon Street, Adair, IA 50002
Finance Budget Code: _____ **Finance Project #** _____
Vendor Project or Invoice #: _____ **PO #** _____
Original Contract Date: May 17, 2021 **Engineer PN #** 08989015

Date of Council Meeting: January 0, 1900 **PAYMENT REQUEST #** 2
PAYMENT PERIOD: From: May 17, 2021 Through: November 12, 2021

Contract Summary

Original Contract Amount:	\$	<u>350,795.99</u>	
Net change by Change Orders:	\$	<u>(655.50)</u>	
Contract Amount to Date: (line 1 ± 2)	\$	<u>350,140.49</u>	
Total completed and stored to date:	\$	<u>340,377.99</u>	
Retainage: <u>5</u> % of Completed Work:	\$	<u>17,018.90</u>	
Total Earned less Retainage:	\$	<u>323,359.09</u>	
Less previous applications for payment:	\$	<u>127,798.56</u>	
SUBTOTAL	\$		<u>195,560.53</u>
OTHER CHARGES (Attach an itemized list)	\$		<u>-</u>
CURRENT PAYMENT DUE	\$		<u>195,560.53</u>
Balance to finish, including retainage:	\$	<u>26,781.40</u>	

Notice to Proceed: May 17, 2021
Substantial Completion: April 1, 2022
Final Completion: May 1, 2022

The undersigned Contractor certifies that to the best of the Contractor's knowledge, information and belief the work covered by this Application for Payment has been completed in accordance with the Contract Documents, that all the amounts have been paid by the Contractor for work for which previous Certificate(s) for Payment were issued and payments received from the Owner, and that current payment shown herein is now due.

Construction Contractor Approval: Caliber Concete, LLC
Firm Name
Michael [Signature] 11/12/21
Signature Date

Engineer / Consultant Approval: MSA Professional Services, Inc.
Firm Name
[Signature] 11/12/2021
Signature Date

Owner Approval: City of Story City
Owner Name

Signature Date

Submit to: _____
E-mail: _____ **Phone:** _____ **Fax:** _____

APPLICATION FOR PARTIAL PAYMENT OF CONTRACT

Previous Applications for Payment

No.	Date	Amount
1	October 4, 2021	\$ 127,798.56
2		
3		
4		
5		
6		
7		
8		
9		
10		
11		
12		
13		
14		
15		
16		
17		
18		
19		
20		
21		
22		
23		
24		
25		
26		
27		
28		
29		
30		
31		
32		
33		
34		
35		

Previous Applications for Payment

No.	Date	Amount
36		
37		
38		
39		
40		
41		
42		
43		
44		
45		
46		
47		
48		
49		
50		
51		
52		
53		
54		
55		
56		
57		
58		
59		
60		
61		
62		
63		
64		
65		
66		
67		
68		
69		
70		

Record of Change Orders

No.	Date	Amount
1	July 16, 2021	\$ (4,070.00)
2	September 29, 2021	\$ 2,299.50
3	October 15, 2021	\$ 1,115.00
4		
5		
6		
7		
8		
9		
10		
11		
12		
13		
14		
15		
16		
17		
18		
19		
20		
21		
22		
23		
24		
25		

CHANGE ORDER TOTAL \$ (655.50)

Contract Time Remaining

Contract Period:	CALENDAR DAYS
Original Contract Date:	5/17/2021
Notice to Proceed:	5/17/2021
Original Contract Time:	319
Added by Change Order:	-
Contract Time to Date:	319
Time Used to Date:	179.00
Contract Time Remaining to Sub:	140.00

PAYMENT TOTAL \$ 127,798.56



INVOICE

Date: November 18, 2021 **Invoice# :** 7931 **Dealer:** TDS

Sold To: Story City Fire Department
504 Broad Street
Story City, IA 50248

Mail To:

This invoice represents the amount due for the Fire Apparatus described below.

Type of Apparatus: Pumper
Chassis Make, Model, (and Year): Spartan Metro Star LFD 10"
Engine Make & Model: Cummins ISL9 450HP
VIN#: 4S9CU2D97NC560602
TID#: 13057

INVOICE AMOUNT:

Contract Amount	\$581,246.02
Chassis Payment	(\$280,593.02)
Change Order #1 (included in contract amount)	\$0.00
Change Order #2	\$6,093.00

Payment Due Upon Delivery **\$306,746.00**

Thank you for your business!

104 Granite Avenue · Breda, IA 51436 · P 712 673 2328 · F 712 673 2200 · www.toyne.com

Built to take the call.

AUTOMOTIVE FIRE APPARATUS CERTIFICATE OF INSPECTION FOR FIRE PUMP SYSTEMS

FIRE EQUIPMENT SERVICES

This is to certify that UL inspected and tested the below apparatus to the certification requirements in Section 16.13.1 of NFPA 1901, Standard for Automotive Fire Apparatus, 2016 Edition.

Certificate No.: 13057		Test Date: 09 December 2021
Date of Issue: 09 December 2021		
Owner/Destination: STORY CITY FIRE DEPT.		Year of Mfr.: 2021
Manufacturer: TOYNE INC.		Mfr. Serial No.: 13057
Mfr. Model: HSC1500		

Chassis Manufacturer		Model Number		Serial Number				
SPARTAN MOTORS		METRO STAR		4S9CU2D97NC560602				
Engine Manufacturer		Model Number		Serial Number				
CUMMINS		ISL		74799263				
Transmission Manufacturer		Model Number		Serial Number				
ALLISON		3000 EVP		6511798573				
Pump Manufacturer		Model Number		Serial Number				
HALE		QMAX150-23L		H30333				
TEST CONDITION								
Barometric Pressure (Hg) Corrected to Sea Level*	Air Temp Before (F)*	Air Temp After (F)*	Pump Elevation Above Water Source (Ft)	Test Site Elevation (Ft)	Water Temp. Before (F) *	Water Temp. After (F) *		
29.6	34	45	5	1394	52	86		
Rated Capacity	Pump Stage		Suction Hose Number	Suction Hose Size (In)	Suction Hose Length (Ft)			
1500	Single Stage		Hose 1	6	20			
Pump Gear Ratio	Pump Location		Hose 2	6	20			
1 : 2.28	Midship		Hose 3	N/A	N/A			
			Hose 4	N/A	N/A			
TEST RESULTS		Pump Control Position	Flow (GPM)	Discharge Pressure (PSI)	Suction Allowance (PSIG)	Net Pump Pressure (PSI)	Pump Speed (RPM)	Engine Speed (RPM)
100% Capacity 150 PSI		Single Stage	1502	149	4.6	154	3202	1404
Overload 165 PSI		Single Stage	1502	162	4.5	166	3298	1447
70% Capacity 200 PSI		Single Stage	1051	197	4.8	202	3443	1510
50% Capacity 250 PSI		Single Stage	750	249	4.7	254	3785	1660
Auto. Pressure Control Max Increase PSI	15	Vacuum: inHg Drop in 5 Minutes Intakes Open		0.0	Vacuum: inHg Drop in 5 Minutes Intakes Closed		0.1	
Water Tank Capacity (Gallons)	750	Gallons Discharged	713	Tank Flowed at (GPM)	509	Time To Prime (Sec):	32	

Engine No-Load Governed Speed: 2200 rpm
 Pressure Gauge Accuracy Test: Passed
 Engine Speed Advancement Interlock Test: Pass

Mfr. Rated No-Load Governed Speed: 2200 rpm
 Flow Meter Accuracy Test: Not Applicable

*Readings for reference only

Remarks:

**For annual in-service testing of your aerial device, ground ladders and pumps, please contact
 UL at 1-877-UL HELPS (877-854-3577)**

Not Valid Unless Signed



George Burghardt,
 UL, LLC

Copyright © 2021 UL LLC.

Unauthorized reproduction, alteration, or recompilation of this certificate constitutes fraud.



CITY OF STORY CITY

504 Broad Street
Story City, IA 50248
515.733.2121

www.cityofstorycity.org



1913 Herschell-Spillman Carousel

To: The Honorable Mayor & City Council

From: Mark A. Jackson, City Administrator 

Re: Reimbursement to Joel Weltha for
City-Owned Farm Land

Date: January 17, 2022

Presented for Mayor and City Council is a request to reimburse Joel Weltha for crop damages and loss of revenue on city-owned farm land as it relates to the Eby Manufacturing Plant 2 Project in the amount of \$11,107.81.

As you are probably aware, Joel Weltha has farmed city-owned farm land in the Interstate 35 Business Park for over 20 years. The general terms of the farm lease state that the City can terminate the lease if the land is needed for economic development purposes, in which event the City shall reimburse Mr. Weltha for all out-of-pocket expenses incurred.

As it relates to the Eby Manufacturing Plant 2 Project, Mr. Weltha incurred expenses in the amount of \$8,864.23. However, I would recommend that Mr. Weltha also receive an additional \$2,243.58 for the loss of net income given the quick time frame of this project, the amount of land disturbed, and that it incurred in the fall of 2021.

Funds would come from the Interstate 35 Business Park Fund.



CLAIMS REGISTER REPORT

By Segment (Select Below)
Payable Dates 12/31/2021 - 1/13/2022

Vendor Name	Description (Payable)	Amount
Department: 1110 - POLICE DEPARTMENT		
MID-STATES ORGANIZED CRI	SAFETY WORKSPACE	100.00
VISA/SC PURCHASING	MISC	149.80
JOHN DEERE FINANCIAL	MISC	89.99
KEY COOPERATIVE	FUEL	658.02
MGMC	MEMBERSHIP	37.80
STORY COUNTY TREASURER	DISPATCH QTR 3 FY 21/22	5,300.89
VERIZON WIRELESS	SERVICE	121.44
COMPLETE COMMUNICATION	PHONE/INTERNET	85.26
		Department 1110 - POLICE DEPARTMENT Total:
		6,543.20
Department: 1150 - FIRE DEPARTMENT		
TOYNE INC	BATTERY	5,149.59
MPEC/NAPA Auto Parts	MISC FIRE	47.02
SAM'S CLUB	BACKPACKS AND REC CENTER	39.98
VISA/SC PURCHASING	MISC	47.40
BLACK HILLS ENERGY	GAS SERVICE	691.47
KEY COOPERATIVE	FUEL	50.09
COMPLETE COMMUNICATION	PHONE/INTERNET	185.43
		Department 1150 - FIRE DEPARTMENT Total:
		6,210.98
Department: 1160 - FIRST RESPONDERS		
BOUND TREE MEDICAL LLC	AED BATTERY	279.98
SAM'S CLUB	BACKPACKS AND REC CENTER	39.98
KEY COOPERATIVE	FUEL	97.97
		Department 1160 - FIRST RESPONDERS Total:
		417.93
Department: 1170 - BLDG INSPECTIONS		
SAFE BUILDING	PERMITS	576.04
SAFE BUILDING	PERMITS	2,005.34
		Department 1170 - BLDG INSPECTIONS Total:
		2,581.38
Department: 1190 - ANIMAL CONTROL		
HEARTLAND PET HOSPITAL	IMPOUND FEES	205.10
		Department 1190 - ANIMAL CONTROL Total:
		205.10
Department: 2210 - STREET/ROADWAY MAINT		
DETROIT INDUSTRIAL TOOL	MISC SUPPLIES	928.69
IOWA STATE UNIVERSITY	2022 WORK ZONE SAFETY	180.00
MPEC/NAPA Auto Parts	MISC STREET	172.31
ZIEGLER	PARTS	1,726.82
SAM'S CLUB	BACKPACKS AND REC CENTER	39.98
VISA/SC PURCHASING	MISC	495.00
BLACK HILLS ENERGY	GAS SERVICE	188.59
JOHN DEERE FINANCIAL	MISC	460.88
JOHN DEERE FINANCIAL	MISC	20.96
KEY COOPERATIVE	FUEL	1,241.13
VERIZON WIRELESS	SERVICE	125.19
AWS SERVICE CENTER	GARBAGE SERVICE	40.00
COMPLETE COMMUNICATION	PHONE/INTERNET	107.58
		Department 2210 - STREET/ROADWAY MAINT Total:
		5,727.13
Department: 2250 - SNOW & ICE		
VISA/SC PURCHASING	MISC	353.60
STORY CITY BLDG PRODUCTS	WOOD	72.86
		Department 2250 - SNOW & ICE Total:
		426.46

CLAIMS REGISTER REPORT

Payable Dates: 12/31/2021 - 1/13/2022

Vendor Name	Description (Payable)	Amount
Department: 4410 - LIBRARY		
AWS SERVICE CENTER	GARBAGE SERVICE	30.00
		Department 4410 - LIBRARY Total:
		<u>30.00</u>
Department: 4430 - PARKS		
MENARDS	LUMBER/HARDWARE	240.19
STORY CITY BLDG PRODUCTS	TREATED LUMBER	44.68
MPEC/NAPA Auto Parts	MISC PARKS	27.47
BLACK HILLS ENERGY	GAS SERVICE	226.79
KEY COOPERATIVE	FUEL	333.31
MGMC	MEMBERSHIP	37.80
VERIZON WIRELESS	SERVICE	101.66
AWS SERVICE CENTER	GARBAGE SERVICE	179.30
COMPLETE COMMUNICATION	PHONE/INTERNET	195.43
LOWES COMPANIES	MISC SUPPLIES	305.35
LEKWA HEATING & COOLING	FVL HVAC	9,595.00
		Department 4430 - PARKS Total:
		<u>11,286.98</u>
Department: 4440 - RECREATION DEPARTMENT		
TREASURER STATE OF IOWA	REC/POOL TAXES	171.20
INTENSITEE INC	PARKS AND REC SHIRTS	22.00
SAM'S CLUB	BACKPACKS AND REC CENTER	29.85
VISA/SC PURCHASING	MISC	69.25
VISA/SC PURCHASING	MISC	500.00
VERIZON WIRELESS	SERVICE	50.83
COMPLETE COMMUNICATION	PHONE/INTERNET	139.53
		Department 4440 - RECREATION DEPARTMENT Total:
		<u>982.66</u>
Department: 4445 - SWIMMING POOL		
AMERICAN RED CROSS	CPR/H2O SAFETY INST.	237.00
BLACK HILLS ENERGY	GAS SERVICE	70.00
STORY CITY MUN ELEC UTILIT	SERVICE	54.04
COMPLETE COMMUNICATION	PHONE/INTERNET	144.53
		Department 4445 - SWIMMING POOL Total:
		<u>505.57</u>
Department: 4450 - CEMETERY		
AWS SERVICE CENTER	GARBAGE SERVICE	40.00
		Department 4450 - CEMETERY Total:
		<u>40.00</u>
Department: 5520 - ECONOMIC DEVELOPMENT		
STORY CITY GCC	2022 PARTNERSHIP	34,650.00
STORY CITY EDC	EDC CONTRIBUTIONS/WATER	316.00
		Department 5520 - ECONOMIC DEVELOPMENT Total:
		<u>34,966.00</u>
Department: 6611 - EXECUTIVE (MAYOR, ADM)		
VISA/SC PURCHASING	MISC	35.00
KEY COOPERATIVE	FUEL	29.14
MGMC	MEMBERSHIP	37.80
		Department 6611 - EXECUTIVE (MAYOR, ADM) Total:
		<u>101.94</u>
Department: 6620 - FINANCIAL AD (CLERK,TREA)		
PETTY CASH	CITY HALL	140.18
COMPASS BUSINESS SOL	PUNCHED PAPER/CHECKS	272.95
COMPASS BUSINESS SOL	PUNCHED PAPER/CHECKS	158.97
DENMAN & COMPANY LLP	SECOND PROGRESS BILLING	3,000.00
DENMAN & COMPANY LLP	PROF. SERV.	500.00
VISA/SC PURCHASING	MISC	49.95
MGMC	MEMBERSHIP	37.80
VERIZON WIRELESS	SERVICE	37.18
COMPLETE COMMUNICATION	PHONE/INTERNET	172.51
		Department 6620 - FINANCIAL AD (CLERK,TREA) Total:
		<u>4,369.54</u>
Department: 6650 - CITY HALL/SENIOR CENTER		
BLACK HILLS ENERGY	GAS SERVICE	446.86

CLAIMS REGISTER REPORT

Payable Dates: 12/31/2021 - 1/13/2022

Vendor Name	Description (Payable)	Amount
AWS SERVICE CENTER	GARBAGE SERVICE	111.20
Department 6650 - CITY HALL/SENIOR CENTER Total:		558.06
Department: 6670 - DATA PROCESSING		
SALTECH	EMAIL/DOMAIN HOSTING	484.00
VISA/SC PURCHASING	MISC	47.40
Department 6670 - DATA PROCESSING Total:		531.40
Department: 8775 - SO & NO PARK PROJECT		
MSA PROFESSIONAL SERVICES	NORTH PARK PHASE 3	190.00
Department 8775 - SO & NO PARK PROJECT Total:		190.00
Department: 9211 - STORM DRAINAGE		
TREASURER STATE OF IOWA	LOST/WW/STORM	532.98
Department 9211 - STORM DRAINAGE Total:		532.98
Department: 9810 - WATER UTILITY		
STORY CITY POSTMASTER	WATER UTILITY BILLS	205.46
TREASURER STATE OF IOWA	WET	2,673.00
HACH COMPANY	FILTER	314.94
BIG STATE INDUSTRIAL SUPPL	GLOVES IMPACT PAINT	747.50
ARAMARK	CLOTHING A.J.	78.93
MPEC/NAPA Auto Parts	MISC	13.17
FERGUSON WATERWORKS #2	SOFTWARE MAINT.	1,850.00
KEYSTONE LABORATORIES	LAB TESTING	50.00
SAM'S CLUB	BACKPACKS AND REC CENTER	39.98
VISA/SC PURCHASING	MISC	40.63
BLACK HILLS ENERGY	GAS SERVICE	127.35
JOHN DEERE FINANCIAL	MISC	95.97
KEY COOPERATIVE	FUEL	167.63
MGMC	MEMBERSHIP	37.80
VERIZON WIRELESS	SERVICE	101.66
STORY CITY MUN ELEC UTILIT	SERVICE	6,569.90
AWS SERVICE CENTER	GARBAGE SERVICE	48.00
COMPLETE COMMUNICATION	PHONE/INTERNET	179.20
Department 9810 - WATER UTILITY Total:		13,341.12
Department: 9815 - SEWER UTILITY		
STORY CITY POSTMASTER	WATER UTILITY BILLS	205.46
TREASURER STATE OF IOWA	LOST/WW/STORM	37.00
AGSOURCE LABORATORIES	TESTING/ WW	148.00
COMPUTER EXPRESS	MONITOR	133.75
CENTRAL IOWA DIST	ICE MELT	228.90
CENTRAL PUMP & MOTOR	SERVICE/ REPAIRS	1,137.51
CENTRAL PUMP & MOTOR	WASTEWATER PUMP REPAIRS	3,104.95
MENARDS	SAMPLE FRIDGE	389.00
ACCUJET LLC	JET VAC LIFT STATIONS	618.26
ACCUJET LLC	JET VAC LIFT STATION	1,700.22
KEYSTONE LABORATORIES	LAB TESTING	546.40
BLACK HILLS ENERGY	GAS SERVICE	186.28
KEY COOPERATIVE	FUEL	193.59
MGMC	MEMBERSHIP	37.80
VERIZON WIRELESS	SERVICE	101.66
STORY CITY MUN ELEC UTILIT	SERVICE	3,096.86
AWS SERVICE CENTER	GARBAGE SERVICE	48.00
COMPLETE COMMUNICATION	PHONE/INTERNET	179.20
BLUE RIBBON PELHAM WATE	DISTILLED WATER	24.00
MSA PROFESSIONAL SERVICES	SUMP PUMP PROG YR 2	89.49
Department 9815 - SEWER UTILITY Total:		12,206.33
Grand Total:		101,754.76

Report Summary

Fund Summary

Fund	Payment Amount
001 - GENERAL FUND	69,330.74
110 - ROAD USE TAX	6,153.59
324 - SO AND NO PARKS PROJECT	190.00
600 - WATER UTILITY	13,341.12
610 - SEWER UTILITY	12,206.33
740 - STORM WATER DRAINAGE	532.98
Grand Total:	101,754.76

Account Summary

Account Number	Account Name	Payment Amount
001-1110-6210	DUES & SUBSCRIPTIONS	137.80
001-1110-6331	MOTOR VEHICLE OPER.	658.02
001-1110-6373	TELEPHONE	206.70
001-1110-6413	PAYMENTS TO OTHER A	5,300.89
001-1110-6504	MINOR EQUIPMENT	239.79
001-1150-6210	DUES & SUBSCRIPTIONS	47.40
001-1150-6331	MOTOR VEHICLE OPER.	50.09
001-1150-6371	UTILITIES	691.47
001-1150-6373	TELEPHONE	185.43
001-1150-6499	MISCELLANEOUS	47.02
001-1150-6504	MINOR EQUIPMENT	5,149.59
001-1150-6506	OFFICE SUPPLIES	39.98
001-1160-6331	MOTOR VEHICLE OPER.	97.97
001-1160-6350	EQUIPMENT REPAIR &	279.98
001-1160-6506	OFFICE SUPPLIES	39.98
001-1170-6490	PROFESSIONAL SERVICE	2,581.38
001-1190-6413	PAYMENTS TO OTHER A	205.10
001-4410-6371	UTILITIES	30.00
001-4430-6210	DUES & SUBSCRIPTIONS	37.80
001-4430-6320	BUILDING & GROUNDS	511.66
001-4430-6331	MOTOR VEHICLE OPER.	333.31
001-4430-6373	TELEPHONE	297.09
001-4430-6499	MISCELLANEOUS	179.30
001-4430-6504	MINOR EQUIPMENT	305.35
001-4430-6507	MISC. OPERATING SUPP	27.47
001-4430-6727	CAPITAL EQUIPMENT	9,595.00
001-4440-6373	TELEPHONE	259.61
001-4440-6413	PAYMENTS TO OTHER A	500.00
001-4440-6418	SALES TAX	171.20
001-4440-6499	MISCELLANEOUS	22.00
001-4440-6507	MISC. OPERATING SUPP	29.85
001-4445-6371	UTILITIES	124.04
001-4445-6373	TELEPHONE	144.53
001-4445-6413	PAYMENTS TO OTHER A	237.00
001-4450-6320	BUILDING & GROUNDS	40.00
001-5520-6413	PAYMENTS TO OTHER A	34,966.00
001-6611-6230	TRAVEL & TRAINING	35.00
001-6611-6331	MOTOR VEHICLE OPER.	29.14
001-6611-6499	MISCELLANEOUS	37.80
001-6620-6373	TELEPHONE	209.69
001-6620-6490	PROFESSIONAL SERVICE	3,500.00
001-6620-6499	MISCELLANEOUS	37.80
001-6620-6506	OFFICE SUPPLIES	481.87
001-6620-6508	PETTY CASH/POSTAGE	140.18
001-6650-6371	UTILITIES	446.86
001-6650-6499	MISCELLANEOUS	111.20
001-6670-6490	PROFESSIONAL SERVICE	484.00

Account Summary

Account Number	Account Name	Payment Amount
001-6670-6506	OFFICE SUPPLIES	47.40
110-2210-6181	CLOTHING ALLOWANCE	460.88
110-2210-6230	TRAVEL & TRAINING	675.00
110-2210-6331	MOTOR VEHICLE OPER.	1,241.13
110-2210-6350	EQUIPMENT REPAIR &	1,726.82
110-2210-6371	UTILITIES	188.59
110-2210-6373	TELEPHONE	232.77
110-2210-6499	MISCELLANEOUS	252.29
110-2210-6507	MISC. OPERATING SUPP	949.65
110-2250-6504	MINOR EQUIPMENT	426.46
324-8775-6490	PROFESSIONAL SERVICE	190.00
600-9810-6181	CLOTHING ALLOWANCE	174.90
600-9810-6210	DUES & SUBSCRIPTIONS	1,887.80
600-9810-6331	MOTOR VEHICLE OPER.	167.63
600-9810-6371	UTILITIES	6,697.25
600-9810-6373	TELEPHONE	280.86
600-9810-6418	SALES TAX	2,673.00
600-9810-6419	DATA PROCESSING	205.46
600-9810-6490	PROFESSIONAL SERVICE	50.00
600-9810-6499	MISCELLANEOUS	88.63
600-9810-6507	MISC. OPERATING SUPP	1,115.59
610-9815-6210	DUES & SUBSCRIPTIONS	37.80
610-9815-6331	MOTOR VEHICLE OPER.	193.59
610-9815-6350	EQUIPMENT REPAIR &	4,242.46
610-9815-6371	UTILITIES	3,283.14
610-9815-6373	TELEPHONE	280.86
610-9815-6418	SALES TAX	37.00
610-9815-6419	DATA PROCESSING	205.46
610-9815-6490	PROFESSIONAL SERVICE	3,236.12
610-9815-6499	MISCELLANEOUS	48.00
610-9815-6507	MISC. OPERATING SUPP	641.90
740-9211-6800	CAPITAL FEE	532.98
	Grand Total:	101,754.76

Project Account Summary

Project Account Key	Payment Amount
None	101,754.76
Grand Total:	101,754.76

**STORY CITY PARKS AND RECREATION DEPARTMENT
MONTHLY ACTIVITIES REPORT
DECEMBER 2021**

- Cole hauled away all old parking lot post from South Park 12/1
- I changed the oil in the 2009 parks Ford F150 12/1
- Cole and I cut all the recycled timbers into 4' sections 12/1
- I filled in at the Rec Center on 12/2
- Cole got a dump truck load of rock on 12/2 to use as base when we set new parking posts in North and South Park
- Cole and I dug the holes for parking lot posts in South Park on 12/6 and 12/7 and started setting post on 12/7-12-9 and finished up South Park on 12/14
- Ice and about 1 inch of snow overnight on 12/10. Cole and I came in at 7am on 12/11 and moved snow at all our locations. Used new snow blower attachment and it worked awesome.
- Fall dance session ended on 12/14. Dance has been held at Fairview Lodge in December due to no heat upstairs of City Hall. Dance will continue at FVL until renovations are complete at City Hall
- Big storm with heavy damaging winds projected for 12/15, so Cole and I put together the wood chipper box we built for the F-350 and got the wood chipper started and ready to go
- Closed Rec center a little early on 12/15 due to tornado warnings and potentially bad weather threats
- Storm wasn't as bad as projected, just had several smaller branches down in parks, boulevards and right of ways. Helped street department pick up branches in streets on 12/16/2021
- 2 Cedar trees were damaged pretty bad in the Cemetery and will need to be removed. Contacted Robb's Tree Service and they will remove soon
- Robb's Tree service took down 2 Cedar trees damaged by storms, 1 pine tree with bad split (was on removal list) and 1 linden with bad split (was on removal list) on 12/17
- Lekwa Heating and Cooling replace the two heaters and A/c units at FVL for the big room on 12/20-12/22. They will come back in the spring to get the A/c units set up
- I was gone 12/23-12/29 (vacation). Back to work on 12/30
- Colby Crutchfield was on call to help Cole with snow removal while I was gone. A little, ice/mix on 12/28 so Colby helped for a couple hours
- Cole started building an 8x8 storage shed that will be utilized at the East baseball diamond this coming season. It will be on skids, so we can move it as needed.

December 2021

Water

Completed Bac-t samples
Completed Well Draw Downs
Completed all One call locates
Completed regular maintenance
Replaced all battery back ups of RO skids and filters
Replaced pre filters in RO 2
Sold Bruce's old truck to Halls
Replaced Hydrant at the corner of Grand and Washington
Worked with Ferguson about meter bid

Wastewater

Weekly & monthly sampling. (TSS, Ammonia, BOD, Tank Samples)

Monthly Maintenance: cleaning, greasing, exercising valves. Calibrated the influent flow meter.

Continued increased Aluminum testing to monitor for regulations coming down the line.

Automatic Systems was out to take a look at SBR Bridge drive Number 2. It keeps tripping out the breaker and causing alarms that have to be taken care of (calls out and caused OT) Replace the heaters on the starter if that doesn't work, we will have to look into it further. *This is still an ongoing problem. We have Josh with central pump lined up to come and see what he can find.

Accu-Jet came and cleaned line from McDonalds to the football field lift station. (LOTS of grease in this line. Should probably be professionally cleaned annually)

Accu-jet also cleaned out both lift stations while they were here.

CIT completed the lining project from Broad to 8th on Hillcrest and Grove

Cut and burned the remaining reed bed.

Applied to reed beds to try and prep for colder weather and difficulties that can come with it.

Serviced snow blower.

Completed 4th quarter quality control testing

Dwain is still working on testing. scheduled wastewater 1 test for Jan 19th

Street Department's Activities for December

1. Put out snow markers
2. Worked on yearly budget
3. Graded gravel lots by soccer fields
4. Swept streets
5. Zeigler serviced CAT front loader
6. Repaired sand door on '09 International truck
7. Ben picked up 2 tons of winter blend cold patch
8. Robb's took down 4 wind damage trees in cemetery
9. Picked up down branches around town from wind storm
10. Finished installing snow fence/had to repair several spots from wind damage
11. Filled several pot holes
12. Washed all pickups and dump trucks
13. Hauled several loads of wood chips
14. Snow and ice control
15. Ben and Mike attended Pesticide Con Ed classes
16. Got all plow trucks ready for winter
17. Got brine trailer and salt spreader ready for winter
18. Winterized street sweeper
19. Maintained brush sites
20. Ty passed CDL course
21. Had 1 traditional burial
22. Christmas and New Year's Holidays

Scheduled Activities for January

1. Snow and ice control
2. Maintain and repair equipment
3. Ty study for pesticide tests
4. Haul compost and wood chips
5. Burn brush at dump sites

Story City Police Department

Summary Report

12/01/2021 00:00:00 - 12/31/2021 23:59:59

Quick Overview

Calls for Service: 448

Outreach Events: 1

Number of Arrests: 0

Traffic Stops: 18

Extra Patrol: 55

Total Charges Filed: 0

New Cases: 23

Fire Alarms: 2

Juvenile Referrals: 0

Calls For Service

Officer Involved

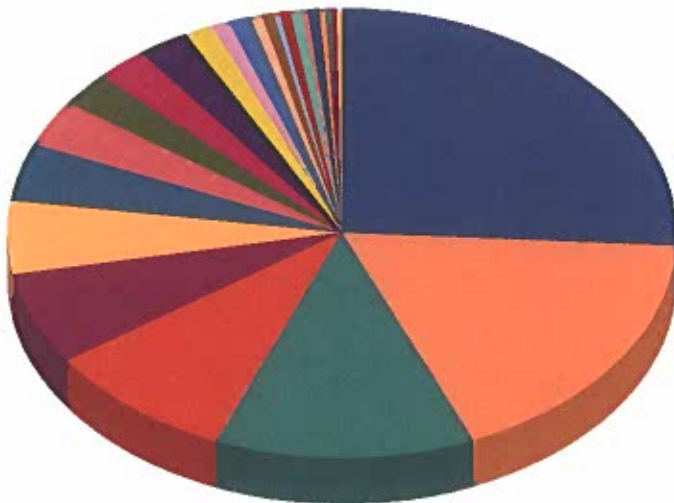

OUTREACH / COMMUNITY SERVICE	25.9%
BUSINESS SECURITY CHECK	17.7%
EXTRA PATROL	12.5%
GENERAL COMPLAINTS	9.1%
SUSPICIOUS ACTIVITY	6.8%
MEDICAL CALL	5.2%
TRAFFIC STOP / ENFORCEMENT	4.1%
COLLISION	3.4%
FOLLOW UP	2.5%
LAW DEPARTMENT ASSIST	2.5%
THEFT/BURGLARY/PROPERTY CALLS	2.5%
WELFARE CHECK	1.4%
ALARM	0.9%
CIVIL MATTER	0.9%
DOMESTIC DISPUTE	0.7%
ADMINISTRATIVE ACTIVITY	0.5%
DEATH INVESTIGATION	0.5%
FIRE OTHER	0.5%
FIRE STRUCTURE	0.5%
HARASSMENT	0.5%
SALVAGE VEHICLE INSPECTION	0.5%
DRUGS AND ALCOHOL	0.2%
GENERAL ASSAULT	0.2%
MISSING PERSON / RUNAWAY	0.2%
VEHICLE FIRE	0.2%
VIOLATION OF NO CONTACT ORDER	0.2%
Total:	100.0%

Events by Day

Officer Involved

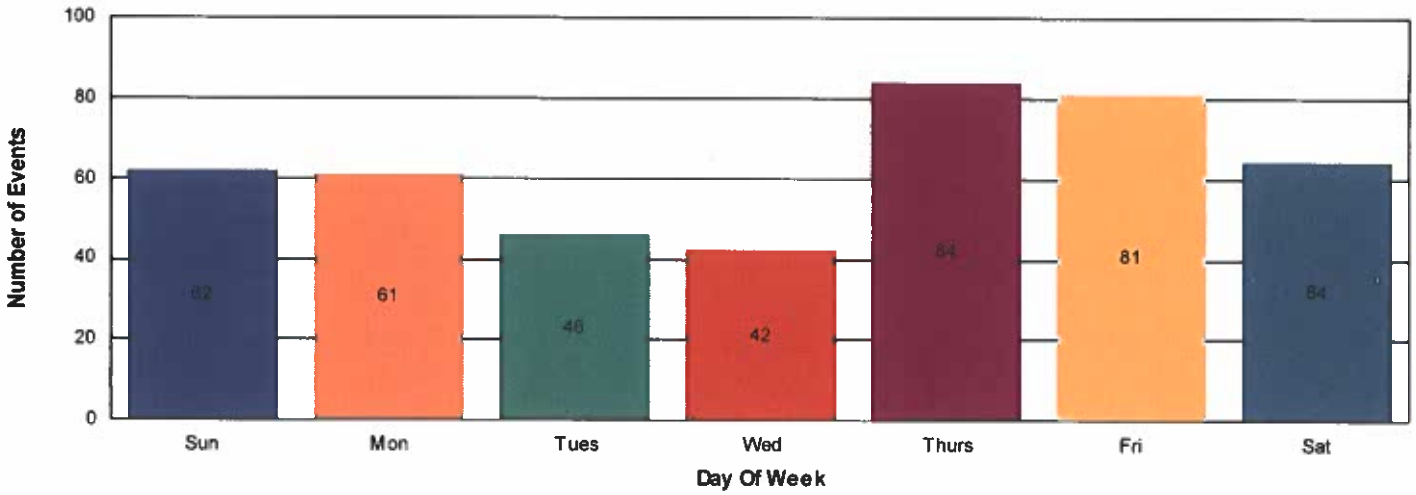

Events by Hour - All Days

Officer Involved

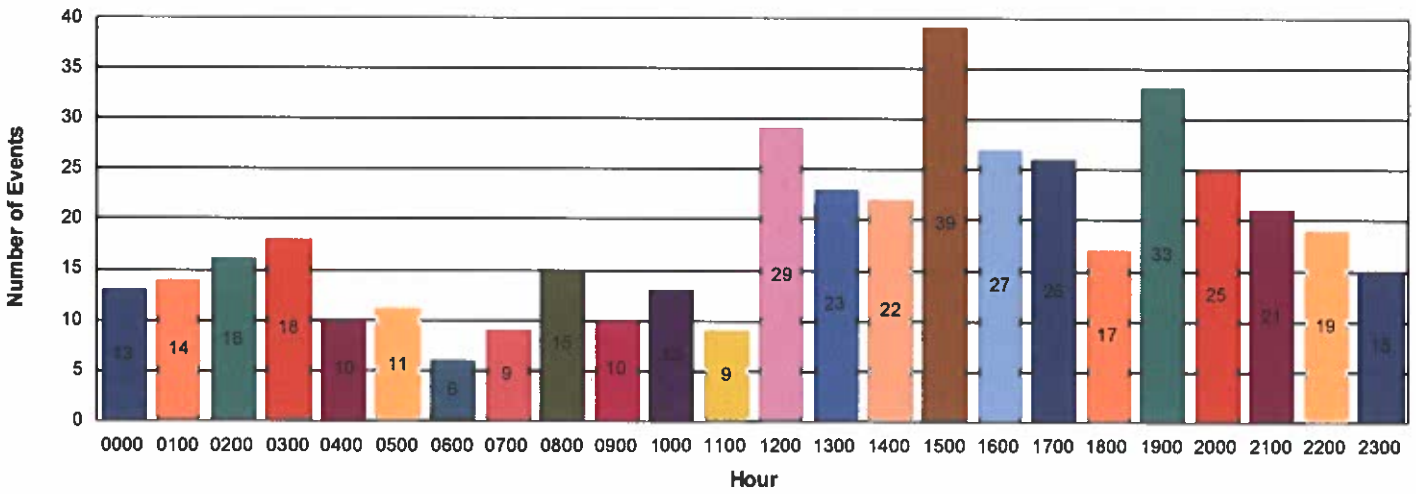

Events by Hour

For Sunday

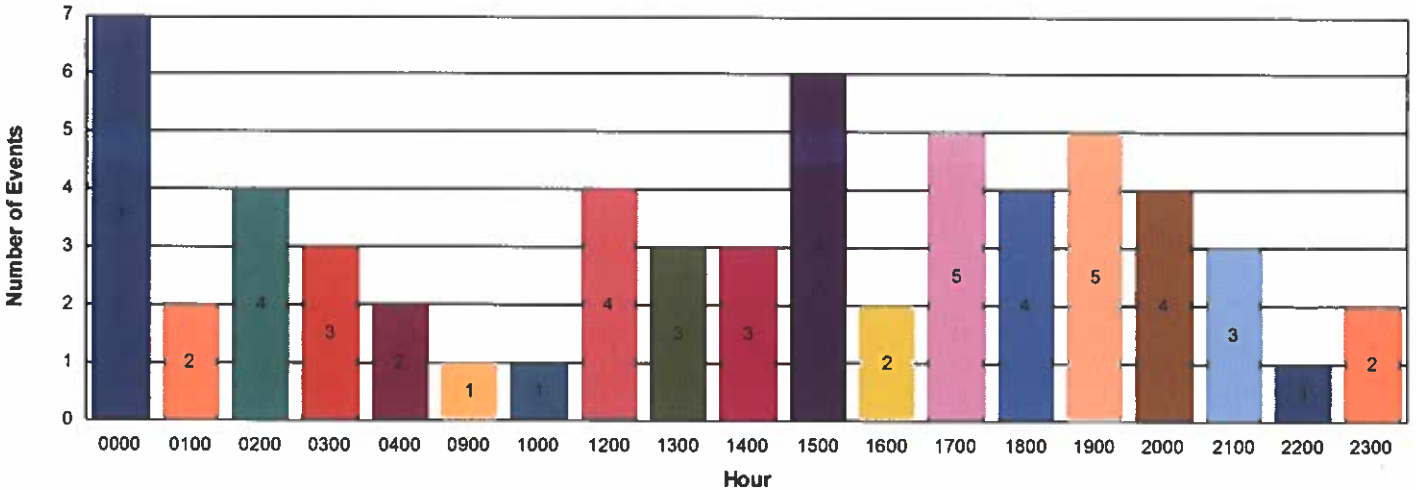

CAD Event Breakdown by Day - All Events

	Sun	Mon	Tues	Wed	Thurs	Fri	Sat	Total
TOTAL	62	61	46	46	87	82	64	448
911 HANG UP / INCOMPLETE CALL	0	0	0	1	0	0	0	1
ANIMAL CALL	1	2	0	1	2	1	1	8
BURGLARY / ATTEMPTED BURGLARY	0	0	0	0	1	0	0	1
BUSINESS SECURITY CHECK	17	6	3	4	8	10	30	78
CHILD WELFARE CHECK	0	0	0	0	1	0	0	1
CITIZEN CONTACT	0	5	3	6	9	6	2	31
CIVIL MATTER	0	0	1	0	1	1	1	4
DEATH INVESTIGATION	0	0	0	0	0	2	0	2
DISTURBANCE & NOISE PARTY	0	0	0	0	0	3	0	3
DOMESTIC DISPUTE	2	1	0	0	0	0	0	3
ELEVATOR ASSIST	1	0	0	0	0	0	0	1
EXTRA PATROL	4	4	5	6	16	17	3	55
FINGER PRINTING	0	0	1	0	2	0	0	3
FIRE ALARM	1	0	1	0	0	0	0	2
FIRE OTHER	0	0	0	0	1	1	0	2
FIRE STRUCTURE	1	0	0	0	0	1	0	2
FOLLOW UP	0	4	1	1	3	2	1	12
GENERAL ALARM BANK / RESIDENTI	0	0	1	1	0	1	0	3
GENERAL ASSAULT	0	0	0	1	0	0	0	1
GENERAL INFO/COMPLAINT/ASSIST	2	0	1	5	1	0	2	11
HARASSMENT	0	0	0	1	1	0	0	2
HIT & RUN PROPERTY DAMAGE	0	0	0	0	0	0	1	1
JUVENILE TROUBLE	0	0	1	0	0	1	0	2
LAW DEPARTMENT ASSIST	1	1	2	1	4	1	1	11
LITTERING	0	0	0	0	1	0	0	1
LOST OR FOUND PROPERTY	0	1	0	0	0	0	0	1
MEDICAL ASSIST/AMBULANCE CALL	1	2	4	3	4	3	6	23
MISSING PERSON / RUNAWAY	0	0	0	0	1	0	0	1
MOTOR VEH CRASH / INJURY	0	0	0	0	0	0	1	1
MOTOR VEH CRASH / UNK INJURY	1	0	0	0	0	0	0	1
MOTOR VEH CRASH/PROP DAMAGE	0	0	2	2	2	5	1	12
MOTORIST ASSISTANCE	0	2	0	1	3	0	0	6
OPEN DOOR	1	0	0	0	0	1	0	2
OPERATING WHILE INTOXICATED	0	0	0	0	0	1	0	1
OUTREACH	0	0	0	0	1	0	0	1
PARKING ENFORCEMENT/COMPLAINT	1	3	0	1	0	1	1	7
RECKLESS DRIVER	4	0	0	1	3	0	1	9
RESIDENCE CHECK	15	16	9	2	12	9	7	70
SALVAGE VEHICLE INSPECTION	0	0	0	0	1	1	0	2
SCAM	0	0	0	0	1	0	0	1
SUSPICIOUS PERSON/VEH/ACTIVITY	5	3	4	0	5	6	5	28
THEFT / FRAUD / FORGERY	1	2	1	1	1	2	0	8
TRAFFIC HAZARD	0	1	0	0	1	0	0	2
TRAFFIC STOP / ENFORCEMENT	2	4	6	3	0	4	0	19
TRAINING	1	1	0	0	0	0	0	2
VEHICLE FIRE	0	1	0	0	0	0	0	1
VEHICLE UNLOCK	0	1	0	1	0	1	0	3
VIOLATION OF NO CONTACT ORDER	0	0	0	1	0	0	0	1
WELFARE CHECK	0	1	0	2	1	1	0	5

Offense Numbers

A report can have more than one offense. The total for this table may be larger than the number of reports listed on page 1.
 This data is from the Mobile database and may not reflect final data in RMS as offenses may change during the approval process.

	Sun	Mon	Tues	Wed	Thurs	Fri	Sat	Total
TOTAL	1	3	2	5	6	6	2	25
ALL OTHER OFFENSES	0	1	0	0	0	0	0	1
ANIMAL ISSUE	0	0	0	0	0	1	0	1
ASSAULT WITH INJURY - SIM/SER ASSAULT	0	0	0	1	0	0	0	1
ASSIST OTHER AGENCY	0	1	0	0	0	1	0	2
BURGLARY 3RD DEGREE - BURGLARY/BREAKING AND ENTERING	0	0	0	0	1	0	0	1
BURGLARY 3RD DEGREE - MOTOR VEHICLE	0	0	0	0	1	0	0	1
COLLISION NO INSURANCE	0	0	0	0	1	0	0	1
COLLISION REPORT	0	0	2	2	1	1	2	8
CRIMINAL MISCHIEF 4TH DEGREE	0	0	0	0	1	0	0	1
DEATH INVESTIGATION	0	0	0	0	0	1	0	1
THEFT 3RD DEGREE - ALL OTHER LARCENY	1	0	0	0	0	0	0	1
THEFT 3RD DEGREE - THEFT FROM MOTOR VEHICLE	0	1	0	0	0	1	0	2
THEFT 4TH DEGREE - ALL OTHER LARCENY	0	0	0	1	0	0	0	1
THEFT 5TH DEGREE - ALL OTHER LARCENY	0	0	0	0	0	1	0	1
THEFT BY DECEPTION - ALL OTHER LARCENY	0	0	0	0	1	0	0	1
VIOLATION OF DOMESTIC ABUSE PROTECTIVE ORDER	0	0	0	1	0	0	0	1

Events by Hour

For Monday

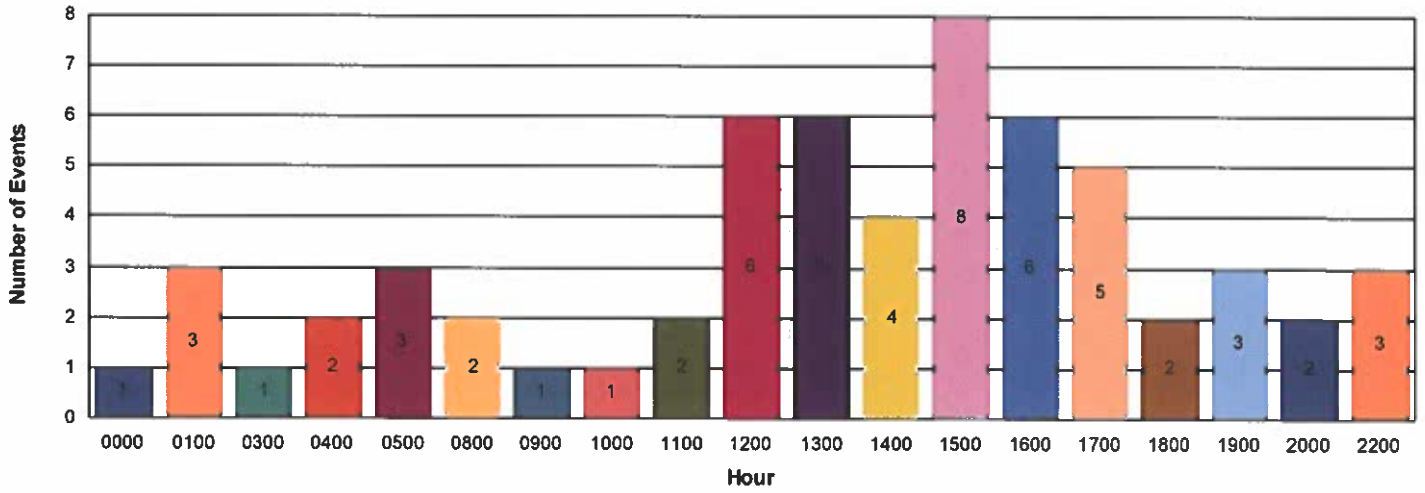

Events by Hour

For Tuesday

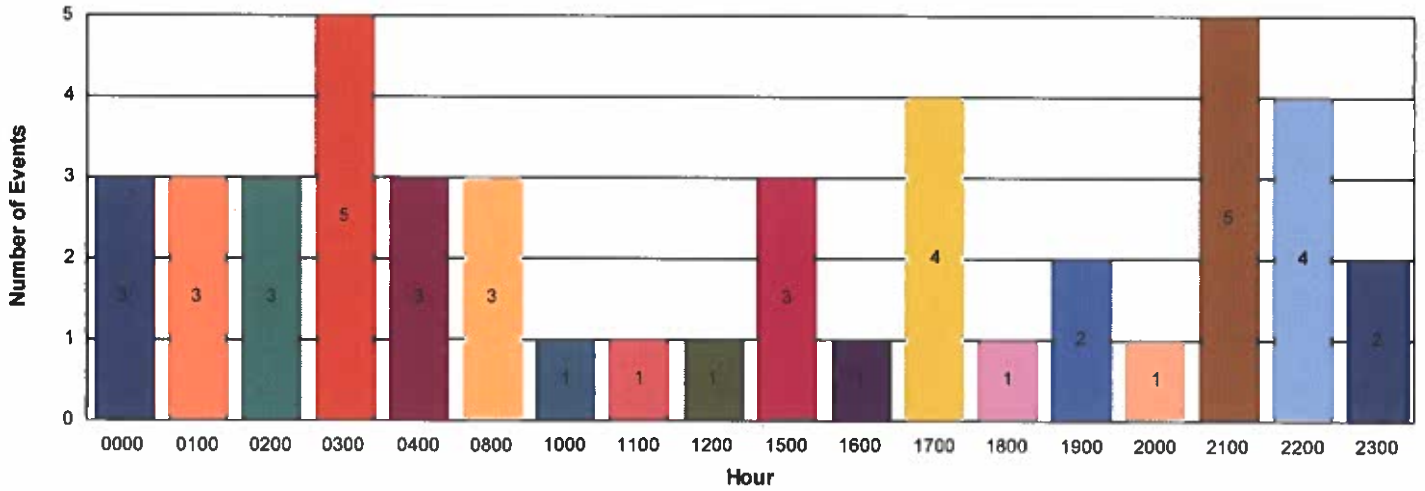

Events by Hour

For Wednesday

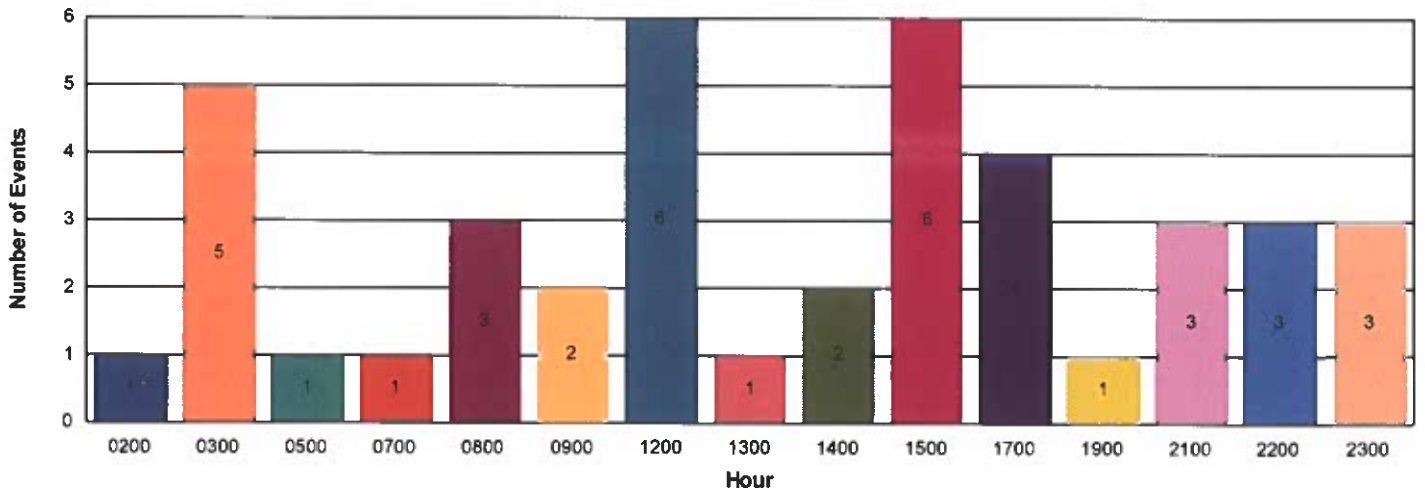

Events by Hour

For Thursday

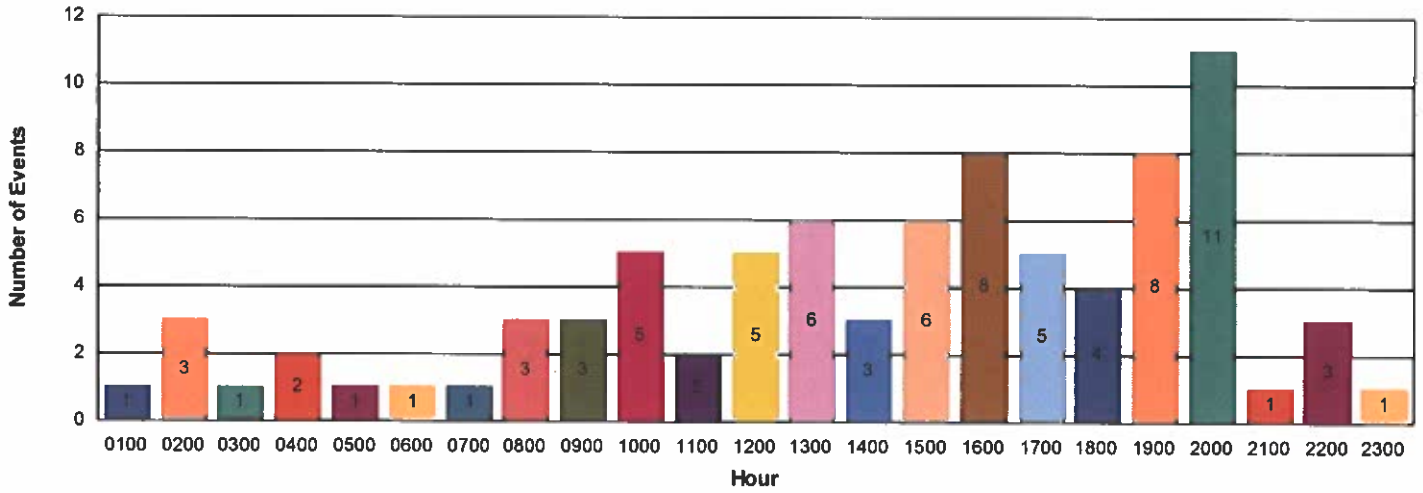

Events by Hour

For Friday

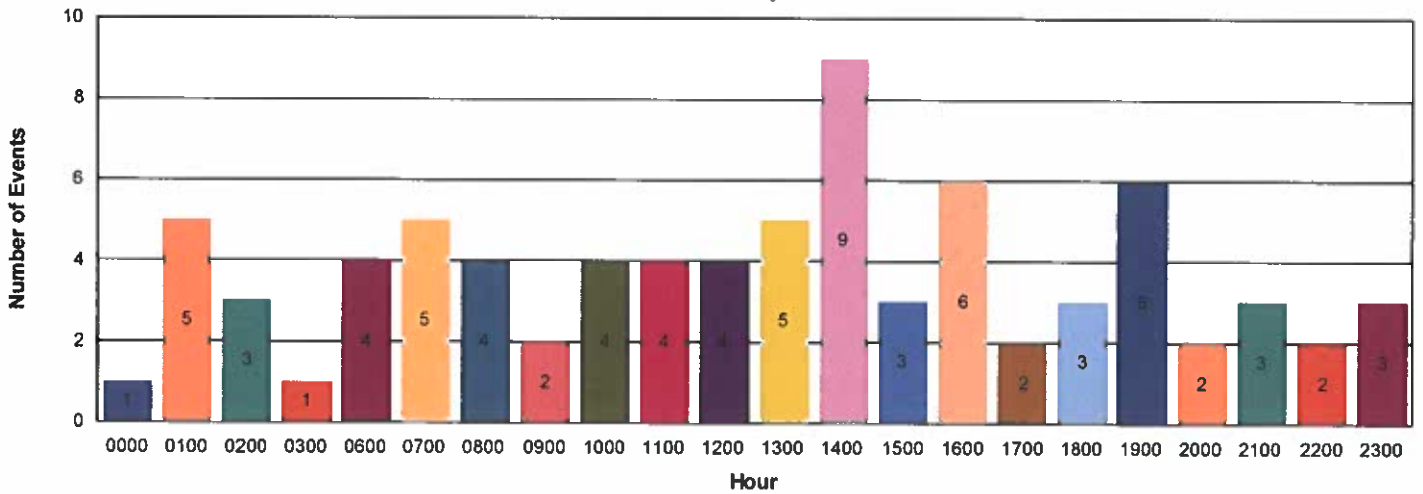

Events by Hour

For Saturday

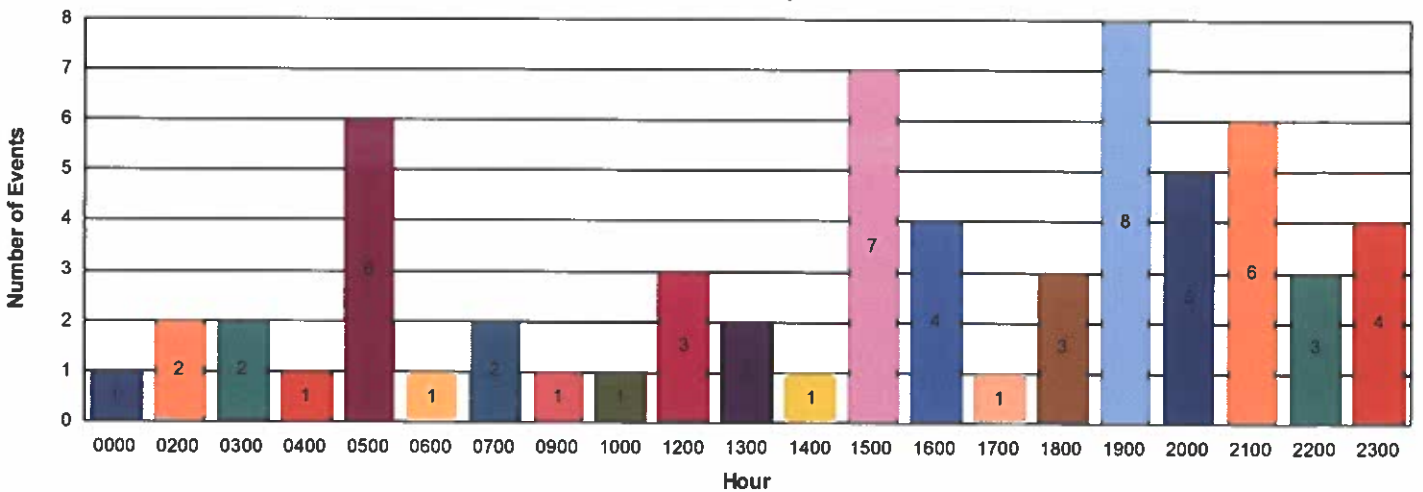

Detail Report

Account Summary

Date Range: 07/01/2021 - 12/31/2021

City of Story City, IA



Account	Name	Beginning Balance	Total Activity	Ending Balance
AccountCode: 1101 - GENERAL SAVINGS ACCOUNT				
<u>001-1101</u>	GENERAL FUND SAV ACCT	576,176.93	1,453.81	577,630.74
<u>022-1101</u>	GENERAL SAVINGS ACCOUNT	0.00	0.00	0.00
<u>031-1101</u>	LIB GIFT TRUST SAV ACCT	107,170.03	105,306.06	212,476.09
<u>032-1101</u>	GENERAL SAVINGS ACCOUNT	0.00	0.00	0.00
<u>040-1101</u>	ECON DEV REV SAV ACCT	210,223.19	424.26	210,647.45
<u>053-1101</u>	GENERAL SAVINGS ACCOUNT	0.00	0.00	0.00
<u>061-1101</u>	GENERAL SAVINGS ACCOUNT	0.00	0.00	0.00
<u>110-1101</u>	GENERAL SAVINGS ACCOUNT	0.00	0.00	0.00
<u>125-1101</u>	GENERAL SAVINGS ACCOUNT	0.00	0.00	0.00
<u>135-1101</u>	GENERAL SAVINGS ACCOUNT	0.00	0.00	0.00
<u>146-1101</u>	GENERAL SAVINGS ACCOUNT	0.00	0.00	0.00
<u>200-1101</u>	DEBT SERVICE SAV ACCT	141,101.44	284.77	141,386.21
<u>350-1101</u>	EQUIP REPL SAV ACCT	15,083.74	30.44	15,114.18
<u>440-1101</u>	GENERAL SAVINGS ACCOUNT	0.00	0.00	0.00
<u>500-1101</u>	CEM PERP CARE SAV ACCT	607.92	1.22	609.14
<u>600-1101</u>	WATER SAV ACCT	104,262.95	263.07	104,526.02
<u>601-1101</u>	WATER SINKING SAVINGS ACCT	79,470.98	200.52	79,671.50
<u>602-1101</u>	WATER IMPROVE SAV ACCT	5,635.85	14.22	5,650.07
<u>610-1101</u>	SEWER SAV ACCT	189,430.79	477.97	189,908.76
<u>612-1101</u>	WW/MO REPL SAV ACCT	164,184.78	307.01	164,491.79
<u>613-1101</u>	SEWER RESERVE FUND SAV ACCT	0.00	0.00	0.00
<u>680-1101</u>	HOSPITAL SAV ACCT	281,304.95	567.71	281,872.66
		1,874,653.55	109,331.06	1,983,984.61
Total AccountCode: 1101 - GENERAL SAVINGS ACCOUNT:				
AccountCode: 1121 - PETTY CASH				
<u>001-1121</u>	PETTY CASH	150.00	0.00	150.00
		150.00	0.00	150.00
Total AccountCode: 1121 - PETTY CASH:				
AccountCode: 1141 - GENERAL CD				
<u>001-1141</u>	GENERAL CD	0.00	0.00	0.00
		0.00	0.00	0.00
Total AccountCode: 1141 - GENERAL CD:				
AccountCode: 1142 - LIBRARY TRUST #5910				
<u>031-1142</u>	LIBRARY TRUST #5910	0.00	0.00	0.00
		0.00	0.00	0.00
Total AccountCode: 1142 - LIBRARY TRUST #5910:				
AccountCode: 1143 - LIBRARY TRUST #5911				
<u>031-1143</u>	LIBRARY TRUST #5911	105,000.00	-105,000.00	0.00
		105,000.00	-105,000.00	0.00
Total AccountCode: 1143 - LIBRARY TRUST #5911:				

Detail Report

Date Range: 07/01/2021 - 12/31/2021

Account	Name	Beginning Balance	Total Activity	Ending Balance
AccountCode: 1147 - CEM PERP CARE CD 500-1147	CEM PERP CARE CD	27,956.90	0.00	27,956.90
Total AccountCode: 1147 - CEM PERP CARE CD:				
AccountCode: 1149 - SEWER CD 610-1149	SEWER CD	0.00	0.00	0.00
Total AccountCode: 1149 - SEWER CD:				
AccountCode: 1160 - HOSPITAL CD 680-1160	HOSPITAL CD	0.00	0.00	0.00
Total AccountCode: 1160 - HOSPITAL CD:				
Grand Totals:		2,007,760.45	4,331.06	2,012,091.51

Fund Summary

Fund	Beginning Balance	Total Activity	Ending Balance
001 - GENERAL FUND	576,326.93	1,453.81	577,780.74
022 - HOUSING ASSISTANCE FUND	0.00	0.00	0.00
031 - LIBRARY GIFT TRUST FUND	212,170.03	306.06	212,476.09
032 - TREES FOREVER PROGRAM	0.00	0.00	0.00
040 - ECON DEV REVOLVING LOAN	210,223.19	424.26	210,647.45
053 - WW/MAINT OPER	0.00	0.00	0.00
061 - SPECIAL ASSISTANCE FUND	0.00	0.00	0.00
110 - ROAD USE TAX	0.00	0.00	0.00
125 - TAX INCREMENT FINANCING	0.00	0.00	0.00
135 - I-35 DEVELOPMENT	0.00	0.00	0.00
146 - AMERICAN RESCUE PLAN	0.00	0.00	0.00
200 - DEBT SERVICE	141,101.44	284.77	141,386.21
350 - EQUIPMENT REPLACEMENT FUND	15,083.74	30.44	15,114.18
440 - RECREATION CENTER	0.00	0.00	0.00
500 - CEMETERY PERPETUAL CARE	28,564.82	1.22	28,566.04
600 - WATER UTILITY	104,262.95	263.07	104,526.02
601 - WATER SINKING	79,470.98	200.52	79,671.50
602 - WATER IMPROVEMENT	5,635.85	14.22	5,650.07
610 - SEWER UTILITY	189,430.79	477.97	189,908.76
612 - SEWER IMP/REPL FUND	164,184.78	307.01	164,491.79
613 - SEWER RESERVE FUND	0.00	0.00	0.00
680 - HOSPITAL ACCOUNT	281,304.95	567.71	281,872.66
Grand Total:	2,007,760.45	4,331.06	2,012,091.51