



# CITY OF STORY CITY

504 Broad Street  
Story City, IA 50248  
515.733.2121  
www.cityofstorycity.org

## **COUNCIL AGENDA** **MONDAY, DECEMBER 20, 2021 - 7:00 P.M.** **COMMUNITY CENTER – 503 ELM AVENUE**

- I. CALL TO ORDER AND ROLL CALL, 7:00 P.M.
- II. APPROVE/AMEND THE AGENDA
- III. APPROVAL OF THE DECEMBER 6, 2021 REGULAR MEETING MINUTES
- IV. CITIZEN APPEARANCE:
  - A)
- V. Public Hearings:
  - A) Proposed Plans, Specifications, Form of Contract, and Estimate of Cost for the City Hall Renovations Project
  - B)
- VI. LEGAL ITEMS:
  - A) Resolution No. 21-98 – Finally Approving and Confirming Plans, Specifications, Form of Contract, and Estimate of Cost for the City Hall Renovations Project
  - B) Resolution No. 21-99 – Accepting Work of Contractor on 2020 Street Improvements North Elm and Factory Outlet Drive Project
  - C) Resolution No. 21-100 – Waiving Joint Review Authority, in Favor of the County, of the Subdivision of Land Owned by Adam and Amber Christian in the Walnut View Subdivision, in Accordance with Section 354.9.2 of the Code of Iowa
  - D) Resolution No. 21-101 – Setting a Public Hearing on the Proposed Amendment to the Fiscal Year 2021-22 Budget
  - E) Ordinance No. 321 – Increasing Fine for Improper Use of a Persons With Disabilities Parking Permit by Amending Section 70.03 of the Code of Ordinances, Final Reading
  - F)
- VII. ADMINISTRATIVE ITEMS:
  - A) Review and Accept Audit for Fiscal Year Ending June 30, 2021
  - B) Approve Underwriting Engagement Letter with D.A. Davidson for 2020 General Obligation Corporate Purpose Bonds

- C) Request Authorization to Sell Truck
- D) Approve Construction Pay Applications No. 4 and No. 5 (Final) for the 2020 Street Improvements North Elm and Factory Outlet Drive Project
- E) Approve Change Order No. 3 for the North Park Phase 3 Improvements Project
- F)

VIII. PERMITS:

- A) Liquor:
  - 1. Ames Center for Health and Harmony – 518 Broad St
  - 2.
- B)

IX. MAYOR & CITY COUNCIL AGENDA ITEMS:

- A)

X. APPROVAL OF BILLS AND CLAIMS

XI. MAYOR AND CITY COUNCIL COMMENTS REGARDING NON-AGENDA ITEMS

XII. ADJOURNMENT

STORY CITY, IOWA

December 6, 2021

Mayor Jensen called the council meeting to order on Monday, December 6, at 7:00 pm at the Community Center.

Present: Mayor Jensen, Administrator Jackson, Attorney Fred Larson  
Council Members, Ostrem, Phillips, Solberg, O'Connor  
Absent: Sporleder

Also Present: Jenny Nelson, Story City Recreation and Aquatics Director

Motion by O'Connor, seconded by Phillips, to approve the agenda.

Aye: Ostrem, Phillips, Solberg, and O'Connor

Nay: None

Motion Carried.

Motion by Solberg, seconded by Ostrem, to approve the November 15, 2021 regular meeting minutes.

Aye: Ostrem, Phillips, Solberg, and O'Connor

Nay: None

Motion Carried.

#### CITIZEN APPEARANCE

None.

#### LEGAL ITEMS

A) **RESOLUTION NO. 21-96 – SETTING DATE FOR A PUBLIC HEARING ON DESIGNATION OF THE EXPANDED STORY CITY CONSOLIDATED URBAN RENEWAL AREA AND ON URBAN RENEWAL PLAN AMENDMENT**

Administrator Jackson presented information on the proposed expansion and amendment to the consolidated urban renewal area.

Motion by Ostrem, seconded by O'Connor, to approve Resolution No. 21-96 – Setting Date for a Public Hearing for January 3, 2022, on Designation of the Expanded Story City Consolidated Urban Renewal Area and on Urban Renewal Plan Amendment

Aye: Ostrem, Phillips, Solberg, and O'Connor

Nay: None

Motion Carried.

B) **RESOLUTION NO. 21-97 – APPROVING AND ADOPTING POLICE DEPARTMENT POLICIES**

Motion by Phillips, seconded by Solberg, to approve Resolution No. 21-97 – Approving and Adopting Police Department Policies

Aye: Ostrem, Phillips, Solberg, and O'Connor

Nay: None  
Motion Carried.

- C) **ORDINANCE NO. 321 – INCREASING FINE FOR IMPROPER USE OF A PERSONS WITH DISABILITIES PARKING PERMIT BY AMENDING SECTION 70.03 OF THE CODE OF ORDINANCES, SECOND READING**  
Motion by Ostrem, seconded by O’Connor, to approve Ordinance No. 321 – Increasing Fine for Improper Use of a Persons With Disabilities Parking Permit by Amending Section 70.03 of the Code of Ordinances, Second Reading  
Aye: Ostrem, Phillips, Solberg, and O’Connor  
Nay: None  
Motion Carried.

### ADMINISTRATIVE ITEMS

- A) **Proposed Swimming Pool Wages for 2022**  
Jenny Nelson recommended proposed wages and other items at the swimming pool for the 2022 season. General discussion was held by council.  
Motion by Solberg, seconded by Phillips, to approve Proposed Swimming Pool Wages and other items for 2022 as presented and recommended.  
Aye: Ostrem, Phillips, Solberg, and O’Connor  
Nay: None  
Motion Carried.
- B) **Approve Payment of Economic Development Grant Payment to Fairview Development, LLC for Timberland Ridge Subdivision**  
Administrator Jackson presented information about the agreement between the City and Fairview Development.  
Motion by Solberg, seconded by Ostrem, to Approve Payment of Economic Development Grant Payment in the amount of \$263,442.35 to Fairview Development, LLC for Timberland Ridge Subdivision  
Aye: Ostrem, Phillips, Solberg, and O’Connor  
Nay: None  
Motion Carried.
- C) **Approve Fiscal Year 2021-22 Property Tax Rebate Payment to Winfield Solutions**  
Administrator Jackson presented information on the agreement between the City and Winfield Solutions. Council had general discussion.  
Motion by O’Connor, seconded by Ostrem, to Approve Fiscal Year 2021-22 Property Tax Rebate Payment to Winfield Solutions in the amount of \$93, 619.  
Aye: Ostrem, Phillips, Solberg, and O’Connor  
Nay: None  
Motion Carried.

## PERMITS

None

## MAYOR & CITY COUNCIL AGENDA ITEMS

### A) Residential Tax Abatements:

1. Adam Lande – 1213 Wicks Way

Motion by Phillips, seconded by O'Connor, to approve Residential Tax Abatement

- Adam Lande – 1213 Wicks Way

Aye: Ostrem, Phillips, Solberg, and O'Connor

Nay: None

Motion Carried.

## APPROVAL OF BILLS AND CLAIMS

Motion by O'Connor, seconded by Solberg, to approve bills and claims.

Aye: Ostrem, Phillips, Solberg, and O'Connor

Nay: None

Motion Carried.

## MAYOR AND CITY COUNCIL COMMENTS REGARDING NON-AGENDA ITEMS

### Administrator Jackson:

- Kwik Star has some site plan questions for the City
- Pre-Bid conference is Dec 7<sup>th</sup> for the City Hall renovations
- There is a 7:15 a.m. school meeting on Dec 7<sup>th</sup> regarding their bond issue
- The ballfields project is moving forward

### CM Solberg:

- What is the status of the grocery store process?

Administrator Jackson: The Economic Development Council is working on this and will let us know when there are updates

There being no further business before council, the meeting adjourned at 7:53 p.m.

ATTEST:

---

Heather Slifka, City Clerk

---

Mike Jensen, Mayor

RESOLUTION NO. 21-98

Resolution finally approving and confirming plans, specifications, form of contract and estimate of cost for the City Hall Renovations Project

WHEREAS, the City Council of the City of Story City, Iowa, has heretofore given preliminary approval to the plans, specifications, form of contract and estimate of cost (the "Contract Documents") for the proposed City Hall Renovations Project (the "Project"), as described in the notice of hearing on the Contract Documents for the Project; and

WHEREAS, a hearing has been held on the Contract Documents on December 20, 2021;

NOW, THEREFORE, Be It Resolved by the City Council of the City of Story City, Iowa, as follows:

Section 1. The Contract Documents referred to in the preamble hereof are hereby finally approved, and the prior action of the City Council giving preliminary approval is hereby finally confirmed, and the Project, as provided for in the Contract Documents, is necessary and desirable.

Section 2. All resolutions or parts of resolutions in conflict herewith are hereby repealed to the extent of such conflict.

Passed and approved December 20, 2021.

---

Mike Jensen, Mayor

Attest:

---

Heather Slifka, City Clerk



It was moved by Council Member \_\_\_\_\_ and seconded by Council Member \_\_\_\_\_ that this meeting be adjourned to January 17, 2022, at 7:00 o'clock p.m., at the Community Center, Story City, Iowa, at which time and place the City Council will meet to further consider such proposals.

The Mayor put the question on the motion and the roll being called, the following named Council Members voted:

Ayes: \_\_\_\_\_

Nays: \_\_\_\_\_.

Whereupon, the Mayor declared the said motion duly carried and the meeting was adjourned to the said time and place.

\_\_\_\_\_  
Mike Jensen, Mayor

Attest:

\_\_\_\_\_  
Heather Slifka, City Clerk



The following resolution was offered by Councilperson \_\_\_\_\_, who moved its adoption.

**RESOLUTION NO. 21-99**

**ACCEPTING WORK OF CONTRACTOR ON 2020 STREET IMPROVEMENTS  
NORTH ELM AND FACTORY OUTLET DRIVE PROJECT**

WHEREAS, the project engineer has reported that work has been completed for the 2020 Street Improvements North Elm and Factory Outlet Drive Project (the "Project") under the contract entered into between the City of Story City, Iowa (the "City"), and Manatt's Inc. (the "Contractor"), and

WHEREAS, in the judgement of this Council, the work appears to meet the requirements of the plans and specifications hereto adopted by the Council for the Project, all as evidenced by the final certificate of completion and estimate of cost, placed on file with the City Clerk.

NOW, THEREFORE, BE IT RESOLVED by the City Council of the City of Story City, Iowa, as follows:

Section 1. The work as completed by the Contractor for the construction of the Project is hereby accepted.

Section 2. Except for the amount being retained by the City pursuant to Chapter 573 of the Code of Iowa, which shall be paid to the contractor not less than 30 days after the acceptance of the work, the amount due to the contractor is hereby ordered paid from available funds from which payment for the Project may be made.

Section 3. All resolutions or parts of resolutions in conflict herewith be and the same are hereby repealed, to the extent of such conflict.

The motion was seconded by Councilperson \_\_\_\_\_, and, upon roll call, was carried by an aye and nay vote, as follows:

AYE: \_\_\_\_\_

NAY: \_\_\_\_\_

ABSENT: \_\_\_\_\_

WHEREUPON, the Mayor declared the Resolution duly adopted this 20<sup>th</sup> day of December, 2021.

\_\_\_\_\_  
Mike Jensen, Mayor

ATTEST: \_\_\_\_\_  
Heather Slifka, City Clerk

# Engineer's Statement of Completion

**Project:** 2020 Street Improvements  
North Elm & Factory Outlet Drive  
Story City, IA

**Contractor:** Manatt's, Inc.  
210 E 13<sup>th</sup> St  
Ames, IA 50010

To City of Story City, Iowa:

I hereby state that the 2020 Street Improvements for North Elm & Factory Outlet Drive in Story City, IA by a Contract dated in June of 2020, has been substantially completed in general compliance with the terms, conditions, and stipulations of said Contract. The work was substantially completed within the specified contract time for the project.

I further state that the total amount due to the Contractor for the fulfillment of said Contract is Two Hundred Nine Thousand Two Hundred Forty-Eight and 10/100 dollars (\$209,248.10). The derivation of this total amount is tabulated on the attached sheets.

This contract was a sales tax exempt project so the Contractor did not pay sales tax and so a certification of the amount of sales tax paid was not required. Ninety-five (95%) of the total amount due the Contractor shall be paid upon authorization by the City. The remaining five percent (5%) shall then be paid no sooner than thirty (30) days following acceptance of the project by the City. The Contractor will receive interest on any unpaid balance at the maximum legal rate from and after forty (40) days following the initial thirty (30) day waiting period following acceptance of the project by the City.

CLAPSADDLE-GARBER ASSOCIATES, INC.



Matt D. Garber, P.E.  
Iowa License No. 14449

Date: November 30, 2021

Accepted by: \_\_\_\_\_  
Resolution: \_\_\_\_\_ Date: \_\_\_\_\_

Distribution: Engineer  
Contractor  
City

Signed: \_\_\_\_\_

Attest: \_\_\_\_\_

The following resolution was offered by Councilperson \_\_\_\_\_ who moved its adoption.

**RESOLUTION NO. 21-100**

**A RESOLUTION WAIVING JOINT REVIEW AUTHORITY, IN FAVOR OF THE COUNTY, OF THE SUBDIVISION OF LAND OWNED BY ADAM AND AMBER CHRISTIAN IN THE WALNUT VIEW SUBDIVISION, IN ACCORDANCE WITH SECTION 354.9.2 OF THE CODE OF IOWA**

WHEREAS, Adam and Amber Christian are the owners of property located in the unincorporated area of Story County, Parcel ID Number 02-04-400-440 of the Walnut View Subdivision; and

WHEREAS, the owner wishes to subdivide the above-described property; and

WHEREAS, the above-described property is located within two miles of the corporate limits of the City of Story City and is subject to joint review authority of the rezoning and subdivision by the City in accordance with Section 354.9.2 of the *Code of Iowa*; and

WHEREAS, Section 354.9.2. of the *Code of Iowa* provides that a local government may, by resolution, waive its joint review authority.

NOW, THEREFORE, BE IT RESOLVED that the Story City City Council does hereby waive its review authority, in favor of the county, for the subdivision of the above-described property.

This motion was seconded by Councilperson \_\_\_\_\_ and, upon roll call, was carried by an aye and nay vote, as follows:

AYE: \_\_\_\_\_

NAY: \_\_\_\_\_

ABSENT: \_\_\_\_\_

WHEREUPON, the Mayor declared the Resolution duly adopted this 20<sup>th</sup> day of December, 2021.

\_\_\_\_\_  
Mike Jensen, Mayor

ATTEST: \_\_\_\_\_  
Heather Slifka, City Clerk

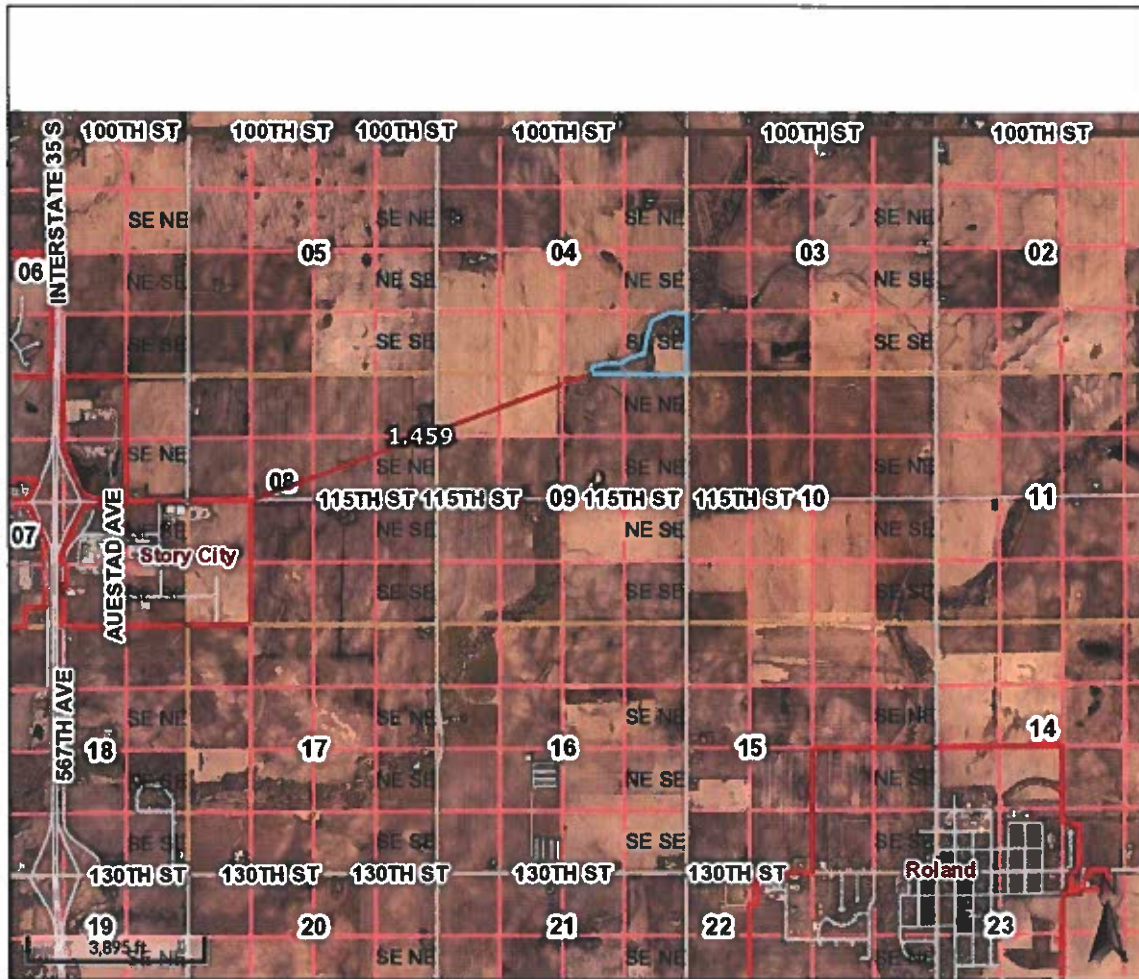

### Overview

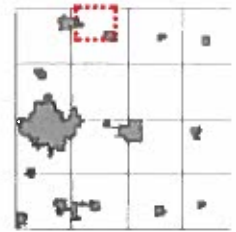

### Legend

- Parcels
- Townships
- Sections
- Quarter Quarters
- Corporate Limits
- Road Centerlines

Parcel ID	0204400440	Alternate ID	0204400440	Owner Address	CHRISTIAN, ADAM J & AMBER L
Sec/Twp/Rng	04-85-23	Class	A - Agriculture		10775 590TH AVE
Property Address	10775 590TH AVE	Acreage	30.41		ROLAND, IA 50236-8068
	ROLAND				

District 53091 - HOWARD TWP/ROLAND-STORY SCH  
 Brief Tax Description SECTION:04 TOWNSHIP:85 RANGE:23 S1/2 SE COMM SE COR SEC 4 N1288.2' 399.2'SW380.1' SW406.3' SW319.3' SW301.2' SW244.7' M227.6' SW374.1' SW164.2' E2042.6' TO BEG  
 (Note: Not to be used on legal documents)

#### Concerning Assessment Parcels and Platted Lots Within the City of Ames Jurisdiction:

The solid parcel boundary lines represent the legal description as recorded and are not necessarily the official platted lot lines. Dashed lines are official platted lots. If a parcel contains dashed lines, please contact the Ames Planning & Housing Department (515-239-5400) to determine which lines can be recognized for building permit or zoning purposes. If you have questions regarding the legal description or parcel measurements, please contact the Story County Auditor's office (515-382-7210).

Date created: 12/10/2021  
 Last Data Uploaded: 12/10/2021 4:35:36 PM

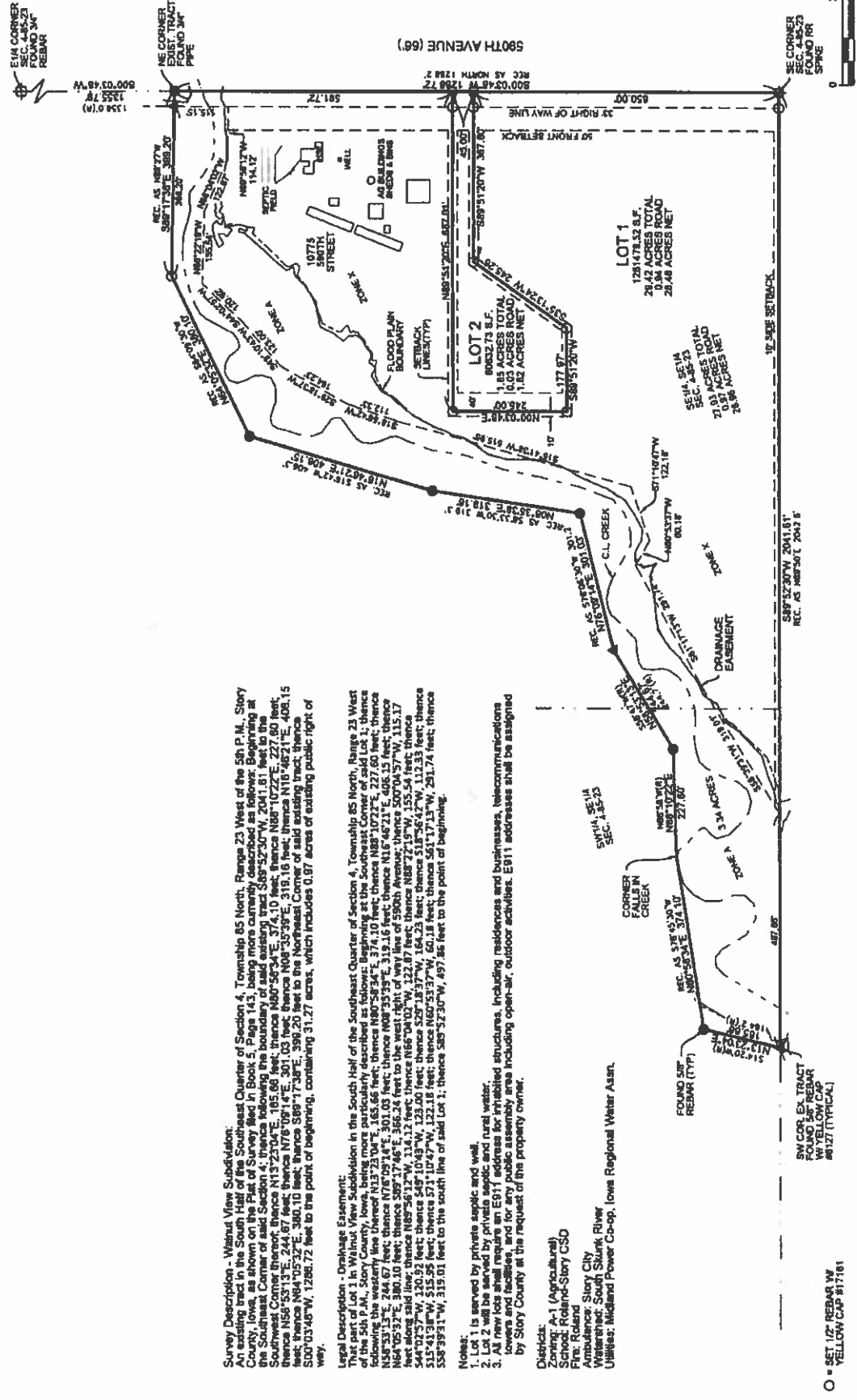

**Survey Description - Walnut View Subdivision:**  
 An existing tract in the South Half of the Southeast Quarter of Section 4, Township 85 North, Range 23 West of the 5th P.M., Story County, Iowa, as shown on the Plat of Survey filed in Book 5, Page 143, being more fully described as follows: Beginning at the Southeast Corner of said Section 4, Township 85 North, Range 23 West of the 5th P.M., Story County, Iowa, and following the westerly line thereof N13°23'04"E, 165.66 feet; thence N80°58'34"E, 374.10 feet; thence N88°10'22"E, 227.60 feet; thence N58°53'13"E, 244.67 feet; thence N76°09'14"E, 301.03 feet; thence N08°33'59"E, 319.16 feet; thence N16°46'21"E, 408.13 feet; thence N54°05'32"E, 380.10 feet; thence S89°17'48"E, 366.24 feet to the west right of way line of 5907th Avenue; thence S07°04'57"W, 115.17 feet along said line; thence N85°56'12"W, 134.12 feet; thence N86°04'02"W, 122.87 feet; thence N86°22'15"W, 155.54 feet; thence S45°12'5"W, 230.92 feet; thence S45°10'49"W, 123.00 feet; thence S27°18'37"W, 64.23 feet; thence S18°36'44"W, 112.33 feet; thence S45°12'5"W, 230.92 feet to the south line of said Lot 1; thence S85°32'30"W, 497.86 feet to the point of beginning.

**Legal Description - Drainage Easement:**  
 A 16-foot wide drainage easement in the South Half of the Southeast Quarter of Section 4, Township 85 North, Range 23 West of the 5th P.M., Story County, Iowa, being more fully described as follows: Beginning at the Southeast Corner of said Lot 1, thence following the westerly line thereof N13°23'04"E, 165.66 feet; thence N80°58'34"E, 374.10 feet; thence N88°10'22"E, 227.60 feet; thence N58°53'13"E, 244.67 feet; thence N76°09'14"E, 301.03 feet; thence N08°33'59"E, 319.16 feet; thence N16°46'21"E, 408.13 feet; thence N54°05'32"E, 380.10 feet; thence S89°17'48"E, 366.24 feet to the west right of way line of 5907th Avenue; thence S07°04'57"W, 115.17 feet along said line; thence N85°56'12"W, 134.12 feet; thence N86°04'02"W, 122.87 feet; thence N86°22'15"W, 155.54 feet; thence S45°12'5"W, 230.92 feet; thence S45°10'49"W, 123.00 feet; thence S27°18'37"W, 64.23 feet; thence S18°36'44"W, 112.33 feet; thence S45°12'5"W, 230.92 feet to the south line of said Lot 1; thence S85°32'30"W, 497.86 feet to the point of beginning.

**Notes:**  
 1. Lot 1 is served by private septic and well.  
 2. Lot 2 will be served by private septic and rural water.  
 3. All new lots shall require an E911 address for inhabited structures, including residences and businesses, telecommunications towers and facilities, and for any public assembly area including open-air, outdoor activities. E911 addresses shall be assigned by Story County at the request of the property owner.

**Districts:**  
 Zoning: A-1 (Agricultural)  
 School: Roland-Story CSO  
 Fire: Roland  
 Ambulance: Story City  
 Utility: Midwest Power Co-op, Iowa Regional Water Assn.



I hereby certify that this land surveying document was prepared by me or under my direct personal supervision and that I am a duly licensed Professional Land Surveyor under the laws of the State of Iowa.

R. BRADLEY STUMBO, PLS  
 License number 17161  
 My license renewal date is December 31, 2021

**FINAL PLAT  
 WALNUT VIEW SUBDIVISION**  
 A RESIDENTIAL PARCEL SUBDIVISION IN THE  
 S1/2, SE1/4 OF SEC. 4-85-23, STORY COUNTY, IOWA  
 JOB# 14374-21A DATE: 10/01/21 PAGE 1 OF 1

**FOX Engineering**  
 FOX Engineering Associates, Inc.  
 414 South 17th Street, Suite 107  
 Ames, Iowa 50010-0000  
 FAX: (515) 233-0103

OWNERS/DEVELOPERS:  
 ADAM J. & AMBER L. CHRISTIAN  
 10775 5907th AVE.  
 ROLAND IA 50236

The following resolution was offered by Councilperson \_\_\_\_\_, who moved its adoption.

**RESOLUTION NO. 21-101**

**A RESOLUTION SETTING A PUBLIC HEARING ON THE PROPOSED AMENDMENT TO THE FISCAL YEAR 2021-22 BUDGET FOR THE CITY OF STORY CITY, IOWA.**

WHEREAS, the City Council of the City of Story City, Iowa, has determined that it is necessary to amend the City’s budget for Fiscal Year 2021-22, and

WHEREAS, a proposed amended budget has been prepared for discussion and further action, and

WHEREAS, it is appropriate and necessary for the City Council to hold a public hearing on said amended budget.

NOW, THEREFORE, BE IT RESOLVED that a public hearing on the proposed amended budget for Fiscal Year 2021-22 will be held at the Community Center in Story City, Iowa, at 7:00 o’clock P.M. on the 3<sup>rd</sup> day of January, 2022, and anyone interested may appear at said time and place to receive information about and express their opinions concerning said amended budget.

BE IT FURTHER RESOLVED that the City Clerk shall cause Notice of said hearing to be published, as required by law.

This motion was seconded by Councilperson \_\_\_\_\_ and, upon roll call, was carried by an aye and nay vote, as follows:

AYE: \_\_\_\_\_

NAY: \_\_\_\_\_

ABSENT: \_\_\_\_\_

WHEREUPON, the Mayor declared the Resolution duly adopted the 20<sup>th</sup> day of December, 2021.

\_\_\_\_\_  
Mike Jensen, Mayor

ATTEST: \_\_\_\_\_  
Heather Slifka, City Clerk

# CITY OF STORY CITY

504 Broad Street  
Story City, IA 50248

515.733.2121

www.cityofstorycity.org



1913 Herschell-Spillman Carousel

To: The Honorable Mayor and City Council

From: Mark A. Jackson, City Administrator *mj*

Re: Resolution No. 21-101 – Amendment to the  
Fiscal Year 2021-22 Budget

Date: December 20, 2021

Presented for Mayor and City Council consideration is a request to set a public hearing for January 3, 2022, on a proposed amendment to the Fiscal Year 2021-22 Budget.

Highlights of the proposed amendment to the Fiscal Year 2021-22 Budget include the following:

## Revenues

- Other City Taxes – projected additional Local Option Sales Tax revenues.
- Intergovernmental – American Rescue Plan funding and reimbursement from the Derecho storm.
- Miscellaneous – Proceeds from the Fran Kinne estate and sale of the spec building.
- Other Financing – Proposed proceeds from bonds for an economic development grant for the purchase of property owned by the Elnora Ritland estate.

## Expenditures

- Community and Economic Development – Proposed economic development grant to the Story City EDC for the purchase of property owned by the Elnora Ritland estate.

- General Government – Replacement of City Hall heating system on the first floor.
- Debt Service – Interest payment on the 2021A bond.
- Capital Projects – Overlay of Broad Street from west corporate limit to Holm Avenue, completion of the Timberland Drive Improvements Project and economic development grant for Timberland Ridge Subdivision, economic grant to Dose Steelworks, completion of the North Park Phase 3 Improvements Project, and slip lining of sanitary sewer mains.
- Business/Enterprise – Membrane replacement at water treatment plant.



**NOTICE OF PUBLIC HEARING - AMENDMENT OF CURRENT BUDGET**

STORY CITY

Fiscal Year July 1, 2021 - June 30, 2022

The City of STORY CITY will conduct a public hearing for the purpose of amending the current budget for fiscal year ending June 30, 2022

**Meeting Date/Time:** 1/3/2022 07:00 PM

**Contact:** Heather Slifka

**Phone:** (515) 733-2121

**Meeting Location:** Community Center - 503 Elm Avenue

There will be no increase in taxes. Any residents or taxpayers will be heard for or against the proposed amendment at the time and place specified above. A detailed statement of: additional receipts, cash balances on hand at the close of the preceding fiscal year, and proposed disbursements, both past and anticipated, will be available at the hearing.

REVENUES & OTHER FINANCING SOURCES		Total Budget as Certified or Last Amended	Current Amendment	Total Budget After Current Amendment
Taxes Levied on Property	1	1,747,871	0	1,747,871
Less: Uncollected Delinquent Taxes - Levy Year	2	0	0	0
Net Current Property Tax	3	1,747,871	0	1,747,871
Delinquent Property Tax Revenue	4	0	0	0
TIF Revenues	5	779,985	0	779,985
Other City Taxes	6	635,392	30,000	665,392
Licenses & Permits	7	45,100	0	45,100
Use of Money & Property	8	77,765	0	77,765
Intergovernmental	9	733,817	265,000	998,817
Charges for Service	10	1,476,200	0	1,476,200
Special Assessments	11	0	0	0
Miscellaneous	12	102,500	1,670,000	1,772,500
Other Financing Sources	13	2,595,000	1,550,000	4,145,000
Transfers In	14	821,723	0	821,723
<b>Total Revenues &amp; Other Sources</b>	<b>15</b>	<b>9,015,353</b>	<b>3,515,000</b>	<b>12,530,353</b>
<b>EXPENDITURES &amp; OTHER FINANCING USES</b>				
Public Safety	16	823,785	0	823,785
Public Works	17	480,050	10,000	490,050
Health and Social Services	18	23,000	0	23,000
Culture and Recreation	19	815,525	10,000	825,525
Community and Economic Development	20	250,800	1,550,000	1,800,800
General Government	21	468,240	40,000	508,240
Debt Service	22	1,055,006	50,000	1,105,006
Capital Projects	23	2,360,000	700,000	3,060,000
Total Government Activities Expenditures	24	6,276,406	2,360,000	8,636,406
Business Type/Enterprise	25	2,257,649	50,000	2,307,649
<b>Total Gov Activities &amp; Business Expenditures</b>	<b>26</b>	<b>8,534,055</b>	<b>2,410,000</b>	<b>10,944,055</b>
Transfers Out	27	821,723	0	821,723
<b>Total Expenditures/Transfers Out</b>	<b>28</b>	<b>9,355,778</b>	<b>2,410,000</b>	<b>11,765,778</b>
<b>Excess Revenues &amp; Other Sources Over (Under) Expenditures/Transfers Out</b>	<b>29</b>	<b>-340,425</b>	<b>1,105,000</b>	<b>764,575</b>
Beginning Fund Balance July 1, 2021	30	5,391,390	0	5,391,390
<b>Ending Fund Balance June 30, 2022</b>	<b>31</b>	<b>5,050,965</b>	<b>1,105,000</b>	<b>6,155,965</b>

**Explanation of Changes:** Revenues: Proceeds from: issuance of bond, Fran Kinne Estate, and sale of spec building. American Rescue Plan and derecho reimbursement funds and additional local option sales tax revenues.  
Expenditures: Street overlay from west corporate limits to Holm Avenue, completion of North Park Phase 3 Improvements Project, completion of Timberland Drive Project and economic grant for Timberland Ridge Subdivision, economic grant to Dose Steelworks, economic grant for purchase of land east of Interstate 35 for economic development purposes, interest payment on 2021A bond, membrane replacement at water treatment plant, slip lining of sanitary sewer main, city hall heating system, and pool repairs.

**ORDINANCE NO. 321**

**AN ORDINANCE INCREASING FINE FOR IMPROPER USE OF A PERSONS WITH DISABILITIES PARKING PERMIT BY AMENDING SECTION 70.03 OF THE CODE OF ORDINANCES OF THE CITY OF STORY CITY, IOWA.**

BE IT ORDAINED BY THE CITY COUNCIL OF THE INCORPORATED CITY OF STORY CITY, IOWA:

SECTION 1. Section 03 of Chapter 70 of the Story City Code of Ordinances (Section 70.03) is hereby repealed in its entirety and replaced with the following:

-----

**70.03 PARKING VIOLATIONS: ALTERNATE.** Uncontested violations of parking restrictions imposed by this Code of Ordinances shall be charged upon a simple notice of a fine payable at the office of the City Clerk. The simple notice of a fine shall be in the amount of twenty-five dollars (\$25.00) for snow emergency parking violations and ten dollars (\$10.00) for all other violations except improper use of a persons with disabilities parking permit. If such fine is not paid within thirty (30) days, it shall be increased by five dollars (\$5.00). The simple notice of a fine for improper use of a persons with disabilities parking permit is two hundred dollars (\$200.00).

-----

SECTION 2. REPEALER. All ordinances or parts of ordinances in conflict with the provisions of this ordinance are hereby specifically repealed.

SECTION 3. SEVERABILITY CLAUSE. If any section, provision or part of this ordinance shall be adjudged invalid or unconstitutional, such adjudication shall not affect the validity of the ordinance as a whole or any section, provision or part thereof not adjudged invalid or unconstitutional.

SECTION 4. WHEN EFFECTIVE. This Ordinance shall be in effect from and after its adoption by the City Council and publication thereof as provided by law.

PASSED, ADOPTED AND APPROVED this 20<sup>th</sup> day of December, 2021.

\_\_\_\_\_  
Mike Jensen, Mayor

\_\_\_\_\_  
ATTEST: Heather Slifka, City Clerk

I hereby certify that the foregoing was published as Ordinance No. 321 on the \_\_\_\_ day of December, 2021.

---

Heather Slifka, City Clerk

MINUTES RE: ORDINANCE 321:

The foregoing Ordinance No. 321 was considered for the first time by the City Council on November 15, 2021. The first reading was moved by Councilperson Sporleder, and seconded by Councilperson Solberg, and, on roll call, carried by an aye and nay vote of the Council, as follows:

AYE: Ostrem, Phillips, Solberg, O'Connor, and Sporleder

NAY:

ABSENT:

The Ordinance was considered for the second time by the City Council on December 6, 2021. The second reading was moved by Councilperson Ostrem, and seconded by Councilperson O'Connor, and, on roll call, carried by an aye and nay vote of the Council, as follows:

AYE: Ostrem, Phillips, Solberg, and O'Connor

NAY:

ABSENT: Sporleder

The Ordinance was considered for the third and final time by the City Council on December 20, 2021. The third and final reading was moved by Councilperson \_\_\_\_\_, and seconded by Councilperson \_\_\_\_\_, and, on roll call, carried by an aye and nay vote of the Council, as follows:

AYE:

NAY:

ABSENT:

WHEREUPON, the Mayor declared Ordinance No. 321 duly passed and the title agreed upon this 20<sup>th</sup> day of December, 2021.

---

Mike Jensen, Mayor

---

ATTEST: Heather Slifka, City Clerk



# CITY OF STORY CITY

504 Broad Street  
Story City, IA 50248  
515.733.2121  
www.cityofstorycity.org

To: The Honorable Mayor & City Council  
From: Mark A. Jackson, City Administrator *MAJ*  
Re: Underwriting Engagement Letter with  
D.A. Davidson for 2022 General Obligation  
Corporate Purpose Bonds  
Date: December 20, 2021

Presented for Mayor & City Council consideration is a request to approve an underwriting engagement letter with D.A. Davidson for the 2022 General Obligation Corporate Bonds.

It is proposed, that the city issue bonds in the amount of approximately \$1.5 million. Proceeds of the bond will be utilized for an economic development grant to the Story City Economic Development Corporation for the purchase of approximately 72+/- acres of land owned by the estate of Elnora Ritland. This property is located east of Winfield Solutions. Proceeds from the bond may also be used for infrastructure improvements.

The Story City Economic Development Corporation, in collaboration with the City of Story City, will purchase the land from the estate of Elnora Ritland in the amount of \$1,550,000. The land will be utilized for future economic development purposes. Financing for the purchase will come from: 1) \$200,000 from the Interstate 35 Business Park fund, and 2) The issuance of a bond. In general, the bond will be paid with Tax Increment Financing revenues over 15 years with interest only payments the first three years. The average payment for the last 12 years is approximately \$142,000. Similar to the spec building, the City will enter into an agreement with the Story City Economic Development Corporation.

In general, and as specifically stated in their engagement letter, D.A. Davidson will provide the following services:

- Identify, contact, and market the bonds to potential investors
- Assist in the preparation of the official statement and other related documents
- Consult with the city's legal counsel
- Negotiate the pricing, including the interest rate, and other terms
- Plan and arrange for the closing and settlement of the bond
- The underwriting fee shall not exceed 1.25% of the principal amount

November 11, 2021

Mayor and Members of the City Council  
City of Story City  
504 Broad Street  
Story City, IA 50248

Re: Underwriting Engagement Letter

Dear Ladies and Gentlemen:

On behalf of D.A. Davidson & Co. (“we” or “Davidson”), thank you for the opportunity to serve as underwriter for the City of Story City, Iowa (the “Issuer”) on the Issuer’s proposed offering and issuance of potentially multiple series of General Obligation Corporate Purpose Bonds, Series 2022 (the “Bonds”). This letter will confirm the terms of our engagement; however, it is anticipated that this letter will be replaced and superseded by a bond purchase agreement to be entered into by the parties (the “Purchase Agreement”) if and when the Bonds are priced following successful completion of the offering process.

1. Services to be Provided by Davidson. The Issuer hereby engages Davidson to serve as managing underwriter of the proposed offering and issuance of the Bonds, and in such capacity Davidson agrees to provide the following services:

- Review and evaluate the proposed terms of the offering and the Bonds
- Develop a marketing plan for the offering, including identification of potential investors
- Assist in the preparation of the official statement and other offering documents
- Contact potential investors, provide them with offering-related information, respond to their inquiries and, if requested, coordinate their due diligence sessions
- If the Bonds are to be rated, assist in preparing materials to be provided to securities ratings agencies and in developing strategies for meetings with the ratings agencies
- Consult with counsel and other service providers about the offering and the terms of the Bonds
- Inform the Issuer of the marketing and offering process
- Negotiate the pricing, including the interest rate, and other terms of the Bonds
- Obtain CUSIP number(s) for the Bonds and arrange for their DTC book-entry eligibility
- Plan and arrange for the closing and settlement of the issuance and the delivery of the Bonds
- Such other usual and customary underwriting services as may be requested by the Issuer

As underwriter, Davidson will not be required to purchase the Bonds except pursuant to the terms of the Purchase Agreement, which will not be signed until successful completion of the pre-sale offering period. This letter does not obligate Davidson to purchase any of the Bonds.

2. **No Advisory or Fiduciary Role.** The Issuer acknowledges and agrees: (i) the primary role of Davidson, as an underwriter, is to purchase securities, for resale to investors, in an arm's-length commercial transaction between the Issuer and Davidson and that Davidson has financial and other interests that may differ from those of the Issuer.; (ii) Davidson is not acting as a municipal advisor, financial advisor, or fiduciary to the Issuer and Davidson has not assumed any advisory or fiduciary responsibility to the Issuer with respect to the transaction contemplated hereby and the discussions, undertakings and procedures leading thereto (irrespective of whether Davidson has provided other services or is currently providing other services to the Issuer on other matters or transactions); (iii) the only obligations Davidson has to the Issuer with respect to the transaction contemplated hereby expressly are set forth in this agreement; and (iv) the Issuer has consulted its own financial and/or municipal, legal, accounting, tax and other advisors, as applicable, to the extent it deems appropriate. If the Issuer desires to consult with and hire a municipal advisor for this transaction that has legal fiduciary duties to the Issuer the Issuer should separately engage a municipal advisor to serve in that capacity.

In addition, the Issuer acknowledges receipt of a letter outlining certain regulatory disclosures as required by the Municipal Securities Rulemaking Board and attached to this agreement as Exhibit A. The Issuer further acknowledges Davidson may be required to supplement or make additional disclosures as may be necessary as the specific terms of the transaction progress.

3. **Fees and Expenses.** Davidson's proposed underwriting fee/spread is 1.250% of the principal amount of the Bonds issued. The underwriting fee/spread will represent the difference between the price that Davidson pays for the Bonds and the public offering price stated on the cover of the final official statement. In addition to the underwriting fee/spread, the Issuer shall pay to Davidson a fee equal to \$2,500 as compensation for its services in assisting in the preparation of the official statement and providing various financial analyses, and for the use of Davidson's capital to advance certain costs prior to settlement, and to reimburse for Davidson's payment of CUSIP, DTC, IPREO (electronic book-running/sales order system), printing and mailing/distribution charges. The Issuer shall be responsible for paying or reimbursing Davidson for all other costs of issuance, including without limitation, bond counsel, disclosure counsel, underwriter's counsel, rating agency fees and expenses, and all other expenses incident to the performance of the Issuer's obligations under the proposed Bonds.

4. **Term and Termination.** The term of this engagement shall extend from the date of this letter to the closing of the offering of the Bonds except as may be superseded pursuant to a Purchase Agreement.

5. **Limitation of Liability.** The Issuer agrees neither Davidson nor its employees, officers, agents or affiliates shall have any liability to the Issuer for the services provided hereunder.

6. **Miscellaneous.** This letter shall be governed and construed in accordance with the laws of the State of Iowa. This Agreement may not be amended or modified except by means of a written



instrument executed by both parties hereto. This Agreement may not be assigned by either party without the prior written consent of the other party.

If there is any aspect of this Agreement that you believe requires further clarification, please do not hesitate to contact us. If the foregoing is consistent with your understanding of our engagement, please sign and return the enclosed copy of this letter.

Again, we thank you for the opportunity to assist you with your proposed financing and the confidence you have placed in Davidson.

Very truly yours,

D.A.DAVIDSON & CO.

By: 

Name: Nathan Summers

Title: Vice President, Public Finance Banker

Accepted this \_\_\_ day of \_\_\_\_\_, 2021

City of Story City, Iowa

By: \_\_\_\_\_

Title: \_\_\_\_\_

## EXHIBIT A

November 1, 2021

Mayor and Members of the City Council  
City of Story City  
504 Broad Street  
Story City, IA 50248

Re: Disclosures by D.A. Davidson & Co. as Underwriter  
Pursuant to MSRB Rule G-17 and G-23  
General Obligation Corporate Purpose Bonds, Series 2022

Dear Ladies and Gentlemen:

We are writing to provide the City of Story City, Iowa ("Issuer"), with certain disclosures required by the Municipal Securities Rulemaking Board (MSRB) Rule G-17 that relate to the proposed offering and issuance of potentially multiple series of General Obligation Corporate Purpose Bonds, Series 2022 (the "Bonds"), which will be used to finance the Issuer's upcoming project.

The Issuer has engaged D.A. Davidson & Co. ("Davidson") to serve as an underwriter, and not as a financial or municipal advisor, in connection with the issuance of the Bonds. As part of our services as underwriter, Davidson may provide advice concerning the structure, timing, terms, and other similar matters concerning the issuance of the Bonds. The specific terms of our engagement will be as set forth in a bond purchase agreement to be entered into by the parties if and when the Bonds are priced following successful completion of the offering process.

1. Dealer-Specific Conflicts of Interest Disclosures

Davidson has not identified any actual or potential material conflicts<sup>1</sup> that require disclosure.

2. Transaction-Specific Disclosures

Since Davidson has not recommended a "complex municipal securities financing" to the Issuer, additional disclosures regarding the financing structure for the Bonds are not required under MSRB Rule G-17. In accordance with the requirements of MSRB Rule G-17, if Davidson recommends a "complex municipal securities financing" to the Issuer, this letter will be supplemented to provide disclosure of the material financial characteristics of that financing structure as well as the material financial risks of the financing that are known to us and reasonably foreseeable at that time.

3. Standard Disclosures

A. Disclosures Concerning the Underwriters' Role:

- (i) MSRB Rule G-17 requires an underwriter to deal fairly at all times with both municipal issuers and investors.

---

<sup>1</sup> Reference to *potential* material conflicts throughout this letter, refer to ones that are reasonably likely to mature into *actual* material conflicts during the course of the transaction, which is the standard required by MSRB Rule G-17

- (ii) An underwriter's primary role is to purchase the Bonds with a view to distribution in an arm's-length commercial transaction with the Issuer. The underwriter has financial and other interests that differ from those of the Issuer.
- (iii) Unlike a municipal advisor, the underwriter does not have a fiduciary duty to the Issuer under the federal securities laws and is, therefore, not required by federal law to act in the best interests of the Issuer without regard to its own financial or other interests.
- (iv) The Issuer may choose to engage the services of a municipal advisor with a fiduciary obligation to represent the Issuer's interest in this transaction.
- (v) The underwriter has a duty to purchase the Bonds from the Issuer at a fair and reasonable price, but must balance that duty with its duty to sell the Bonds to investors at prices that are fair and reasonable.
- (vi) The underwriter will review the official statement for the Bonds in accordance with, and as part of, its respective responsibilities to investors under the federal securities laws, as applied to the facts and circumstances of this transaction.<sup>2</sup>

**B. Disclosures Concerning the Underwriters' Compensation:**

- (i) The underwriter will be compensated by a fee and/or an underwriting discount that will be set forth in the bond purchase agreement to be negotiated and entered into in connection with the issuance of the Bonds. Payment or receipt of the underwriting fee or discount will be contingent on the closing of the transaction and the amount of the fee or discount may be based, in whole or in part, on a percentage of the principal amount of the Bonds. While this form of compensation is customary in the municipal securities market, it presents a conflict of interest since the underwriter may have an incentive to recommend to the Issuer a transaction that is unnecessary or to recommend that the size of the transaction be larger than is necessary.

**4. Questions and Acknowledgment.**

Davidson is registered as a broker-dealer with the U.S. Securities and Exchange Commission ("SEC") and the MSRB, and is subject to the regulations and rules on municipal securities activities established by the SEC and MSRB. The website address for the MSRB is [www.msrb.org](http://www.msrb.org). The MSRB website includes educational material about the municipal securities market, as well as an investor brochure that describes the protections that may be provided by the MSRB rules and how to file a complaint with an appropriate regulatory authority.

If you or any other Issuer officials have any questions or concerns about these disclosures, please make those questions or concerns known immediately to the undersigned. In addition, you should consult with

---

<sup>2</sup> Under federal securities law, an issuer of securities has the primary responsibility for disclosure to investors. The review of the official statement by the underwriter is solely for purposes of satisfying the underwriter's obligations under the federal securities laws and such review should not be construed by an issuer as a guarantee of the accuracy or completeness of the information in the official statement.

the Issuer's own financial and/or municipal, legal, accounting, tax and other advisors, as applicable, to the extent you deem appropriate.

It is our understanding that you have the authority to bind the Issuer by contract with us, and that you are not a party to any disclosed conflict of interest relating to the subject transaction. If our understanding is incorrect, please notify the undersigned immediately.

We are required to seek your acknowledgement that you have received this letter. Accordingly, please send me an email to that effect, or sign and return the enclosed copy of this letter to me at the address set forth below. Otherwise, an email read receipt from you or automatic response confirming that our email was opened by you will serve as an acknowledgement that you received these disclosures.

Depending on the structure of the transaction that the Issuer decides to pursue, or if additional actual or potential material conflicts are identified, we may be required to send you additional disclosures regarding the material financial characteristics and risks of such transaction and/or describing those conflicts. At that time, we also will seek your acknowledgement of receipt of any such additional disclosures.

Again, we thank you for the opportunity to assist you with your financing and the confidence you have placed in us.

D.A. DAVIDSON & CO.

By: 

Name: Nathan Summers

Title: Vice President, Public Finance Banker

Acknowledged this \_\_\_ day of \_\_\_\_\_, 2021

City of Story City, Iowa

By: \_\_\_\_\_

Title: \_\_\_\_\_

# CITY OF STORY CITY

504 Broad Street  
Story City, IA 50248  
515.733.2121

[www.cityofstorycity.org](http://www.cityofstorycity.org)

1913 Herschell-Spillman Carousel

To: The Honorable Mayor & City Council  
From: Randy Martindale, Water and Wastewater Superintendent  
Re: Request Authorization to Sell Truck  
Date: December 20, 2021

Brian Hill from Hall Excavating would like to purchase the 2000 box truck that was the vehicle used by former Streets Superintendent Bruce Henrichs, which is now used by the water and wastewater department.

The truck is beginning to have mechanical issues that are going to be too costly to repair, and the snow blade that goes with the truck no longer works. I spent approximately \$1,500 on fixing the snow blade last year and this year it doesn't work. I do not want to continue to sink money into this truck and blade. I have looked up book value on this truck and it has a value between \$1,500 and \$2,000. Brian said he would purchase it for \$2,000. We have a new truck on order that should be in any time. I think letting Halls purchase it is good for us too, they do all of our water main repairs and they would use this truck during those repairs to store equipment.

Thank You for your consideration

## Construction Pay Application No. 4

**Project Description:** 2020 Street Improvements North Elm & Factory Outlet Drive  
 Project No.: 1685  
**Date of Contract:** June 18, 2020

**Contractor:**  
 Manatt's, Inc.  
 210 E 13th St, Ames, IA 50010

**Owner:**  
 City of Story City Iowa  
 504 Broad Street, Story City, IA 50248

Total Base Bid	\$187,464.00	Construction Completed to Date	\$209,248.10
Change Order #1	\$49,685.65	Materials Stored to Date (See Attached Tab)	\$0.00
Change Order #2	\$3,300.00		
Change Order #3	\$14,948.50		
		Total Amount Earned to Date	\$209,248.10
		Less Previous Payments	\$193,418.02
		Less Retainage	5.0% <u>\$10,462.41</u>
<b>TOTAL CONTRACT PRICE</b>	<b>\$255,398.15</b>	<b>AMOUNT DUE THIS ESTIMATE</b>	<b>\$5,367.68</b>

**Requested by Contractor:**

Ashley Hint      Contract Admin      12/18/21  
 Manatt's Inc.      Title      Date

**Recommended by Engineer:**

Garrett T. Jacobs      Design Engineer      12/8/21  
 Garrett T. Jacobs      Title      Date  
 Clapsaddle-Garber Associates, Inc.

**Approved by Owner:**

\_\_\_\_\_  
 City of Story City      Title      Date

## Construction Pay Application No. 5

**Project Description:** 2020 Street Improvements North Elm & Factory Outlet Drive  
**Date of Contract:** Project No.: 1685  
 June 18, 2020

**Contractor:**  
 Manatt's, Inc.  
 210 E 13th St, Ames, IA 50010

**Owner:**  
 City of Story City Iowa  
 504 Broad Street, Story City, IA 50248

Total Base Bid	\$187,464.00	Construction Completed to Date	\$209,248.10
Change Order #1	\$49,685.65	Materials Stored to Date	
Change Order #2	\$3,300.00	(See Attached Tab)	\$0.00
Change Order #3	\$14,948.50		
		Total Amount Earned to Date	\$209,248.10
		Less Previous Payments	\$198,785.70
		Less Retainage	0.0% <u>\$0.00</u>
<b>TOTAL CONTRACT PRICE</b>		<b>AMOUNT DUE THIS ESTIMATE</b>	<b><u>\$10,462.41</u></b>
	<u>\$255,398.15</u>		

*Requested by Contractor:*

Ashley Hint      Contract Adm      12/8/21  
 Manatt's Inc.      Title      Date

*Recommended by Engineer:*

Garrett Jacobs      Design Engineer      12/8/21  
 Garrett T. Jacobs      Title      Date  
 Clapsaddle-Garber Associates, Inc.

*Approved by Owner:*

\_\_\_\_\_  
 City of Story City      Title      Date

PROJ: 2020 Street Improvements North Elm & Factory Outlet Drive  
PK: 1655.08

APPLICATION FOR PAYMENT  
UNIT PRICE CONTRACT

APPLICATION NO: #4  
APPLICATION DATE: 11/16/2021  
FOR PERIOD: 10/01/21 TO 11/29/21

A	B	C	E	F	G	H	I	J	K	L	M	N	O	P
UNITS	QTY	UNIT PRICE	CONTRACT PRICE	TOTAL QTY PREVIOUS APPLICATION	TOTAL AMOUNT PREVIOUS APPLICATION	TOTAL AMOUNT THIS PERIOD	WORK COMPLETED	AMOUNT THIS PERIOD	MATERIALS PREVIOUSLY STORED (B AMOUNT)	TOTAL CITY TO DATE	TOTALS AMOUNT COMPLETED AND STORED TO DATE	% (M/F)	BALANCE TO FINISH (M/F)	RETAINAGE (O/S)
North Elm Ave														
6/01	ADJUSTMENT OF EXISTING MANHOLE AND CONCRETE BOULDER	EA	1	\$2,700.00	\$2,700.00	1	0	\$0.00	0	0	\$2,700.00	100%	\$0.00	\$152.00
7/01-1	HMA MILLING, 2 INCH	BY	1,266	\$4.26	\$5,391.78	0	0	\$0.00	0	0	\$5,391.78	0%	\$5,391.78	\$0.00
7/01-2	HMA OVERLAY, 3 INCH	TONS	126	\$87.00	\$11,052.00	156	0	\$0.00	0	0	\$11,052.00	100%	\$0.00	\$532.00
7/01-3	HMA PATCHER, 3 INCH	BY	246	\$4.00	\$984.00	0	0	\$0.00	0	0	\$984.00	0%	\$984.00	\$0.00
7/01-4	PCC CURB AND GUTTER, 3 INCH WALK	LF	475	\$38.00	\$18,115.00	26	0	\$0.00	0	0	\$18,141.00	100%	\$0.00	\$53.70
7/01-5	PCC CURB AND GUTTER, 3 INCH WALK	LF	475	\$38.00	\$18,115.00	483	0	\$0.00	0	0	\$18,598.00	100%	\$0.00	\$383.85
7/01-6	PCC DRIVEWAY, 4 INCH WALK	LF	20	\$1,200.00	\$24,000.00	20	0	\$0.00	0	0	\$24,000.00	100%	\$0.00	\$200.00
7/01-7	PCC DRIVEWAY, 4 INCH WALK	LF	20	\$1,200.00	\$24,000.00	20	0	\$0.00	0	0	\$24,000.00	100%	\$0.00	\$200.00
7/01-8	TRAFFIC CONTROL	EA	1	\$1,500.00	\$1,500.00	1	0	\$0.00	0	0	\$1,500.00	100%	\$0.00	\$100.00
7/01-9	TRAFFIC CONTROL	EA	1	\$1,500.00	\$1,500.00	1	0	\$0.00	0	0	\$1,500.00	100%	\$0.00	\$100.00
7/01-10	MOBILIZATION	EA	1	\$4,000.00	\$4,000.00	1	0	\$0.00	0	0	\$4,000.00	100%	\$0.00	\$300.00
7/01-11	ADJUSTMENT OF EXISTING MANHOLE AND CONCRETE BOULDER	EA	2	\$2,700.00	\$5,400.00	2	0	\$0.00	0	0	\$5,400.00	100%	\$0.00	\$270.00
7/01-12	HMA MILLING, 2 INCH	BY	2,260	\$4.26	\$9,628.20	2743	0	\$0.00	0	0	\$12,356.40	102%	\$-2,728.20	\$0.00
7/01-13	HMA OVERLAY, 3 INCH	TONS	240	\$87.00	\$21,048.00	438.77	0	\$0.00	0	0	\$21,786.77	104%	\$-738.77	\$0.00
7/01-14	HMA PATCHER, 3 INCH	BY	480	\$4.00	\$1,920.00	17.88	0	\$0.00	0	0	\$1,937.88	3%	\$1,921.12	\$0.00
7/01-15	PCC CURB AND GUTTER, 3 INCH WALK	LF	60	\$38.00	\$2,280.00	6	0	\$0.00	0	0	\$2,286.00	9%	\$1,993.00	\$0.00
7/01-16	PCC CURB AND GUTTER, 3 INCH WALK	LF	60	\$38.00	\$2,280.00	6	0	\$0.00	0	0	\$2,286.00	9%	\$1,993.00	\$0.00
7/01-17	REMOVAL OF EXISTING PCC CURB AND GUTTER	LF	60	\$15.00	\$900.00	0	0	\$0.00	0	0	\$900.00	0%	\$900.00	\$0.00
8/02	TRAFFIC CONTROL	EA	1	\$4,000.00	\$4,000.00	1	0	\$0.00	0	0	\$4,000.00	100%	\$0.00	\$200.00
8/03	TRAFFIC CONTROL	EA	1	\$4,000.00	\$4,000.00	1	0	\$0.00	0	0	\$4,000.00	100%	\$0.00	\$200.00
8/04	TRAFFIC CONTROL	EA	1	\$4,000.00	\$4,000.00	1	0	\$0.00	0	0	\$4,000.00	100%	\$0.00	\$200.00
11/02	MOBILIZATION	EA	1	\$4,000.00	\$4,000.00	1	0	\$0.00	0	0	\$4,000.00	100%	\$0.00	\$300.00
ORIGINAL CONTRACT TOTALS														
													\$5,392.58	\$1,200.00

Change Order No. 1

CO1-1	GRANULAR BROKERS, TYPE B	TONS	200.00	\$27.00	\$5,400.00	215.2	0	\$0.00	0	0	\$5,415.20	100%	\$0.00	\$200.00
CO1-2	CLEANING AND PREPARATION OF BASE	BY	0.20	\$500.00	\$100.00	0.2	0	\$0.00	0	0	\$100.00	100%	\$0.00	\$10.00
CO1-3	PAVEMENT REPAIR/CONTROL	BY	242.00	\$8.70	\$2,105.40	337.31	0	\$0.00	0	0	\$2,252.71	135%	\$-1,147.31	\$140.00
CO1-4	HMA, ST. INTERMEDIATE COURSE, 1/2 IN. WALK	TONS	242.00	\$50.00	\$12,100.00	193.14	0	\$0.00	0	0	\$9,867.00	89%	\$2,233.00	\$400.00
CO1-5	HMA, ST. SURFACE COURSE, 1/2 IN. WALK, NO SPECIAL FRACTION	TONS	242.00	\$50.00	\$12,100.00	290	0	\$0.00	0	0	\$14,500.00	120%	\$-2,400.00	\$700.00
CO1-6	ASPHALT SAND, PG 4-22A, STANDARD TRAFFIC	TONS	24.00	\$400.00	\$9,600.00	25.00	0	\$0.00	0	0	\$11,815.00	89%	\$1,795.00	\$0.00
CO1-10	PAINTED PAVEMENT MARKINGS, WATERBORNE/SOLVENT	BY	20.50	\$30.50	\$625.25	10.814	0	\$0.00	0	0	\$337.40	107%	\$-287.85	\$33.35
CO1-11	TRAFFIC CONTROL	EA	1.00	\$500.00	\$500.00	1	0	\$0.00	0	0	\$500.00	100%	\$0.00	\$25.00
CO1-12	FLAGGER	EA	4.00	\$500.00	\$2,000.00	4	0	\$0.00	0	0	\$2,000.00	100%	\$0.00	\$121.00
CO1-13	PILOT CAR	DAY	1.00	\$800.00	\$800.00	1	0	\$0.00	0	0	\$800.00	100%	\$0.00	\$43.25
CO1-14	MOBILIZATION	EA	1.00	\$500.00	\$500.00	1	0	\$0.00	0	0	\$500.00	100%	\$0.00	\$35.00
CHANGE ORDER 1 CONTRACT TOTALS														
													\$40,813.02	\$1,717.63

Change Order No. 2 (Perk. and Cedar Pkch)

7/05	HMA PATCHER, FULL-DEPTH	BY	64.00	\$50.00	\$3,200.00	43	0	\$0.00	0	0	\$3,243.00	73%	\$-800.00	\$120.00
CHANGE ORDER 2 CONTRACT TOTALS														
													\$2,400.00	\$800.00

Change Order No. 3 (Elm Avenue Overlay Adjustments)

7/01-1	HMA MILLING, 2 INCH	BY	1,296.00	\$4.26	\$5,502.96	0	0	\$0.00	0	0	\$5,502.96	0%	\$5,502.96	\$0.00
CO3-7/01	EXISTING ROADWAY MILLING, 5 INCH	BY	1,266.00	\$110.00	\$139,260.00	1,301	0	\$0.00	0	0	\$139,260.00	100%	\$0.00	\$650.00
7/01-2	HMA OVERLAY, 3 INCH	TONS	24.00	\$87.00	\$2,108.40	22.43	0	\$0.00	0	0	\$2,071.94	90%	\$236.46	\$103.50
CO3-7/02	HMA BASE COURSE, 3 INCH	TONS	213.00	\$44.40	\$9,457.20	208.18	0	\$0.00	0	0	\$19,444.01	89%	\$-1,013.19	\$0.00
7/05-1	HMA PATCHER, FULL-DEPTH	BY	330.00	\$40.00	\$13,200.00	0	0	\$0.00	0	0	\$13,200.00	0%	\$13,200.00	\$0.00
CHANGE ORDER 3 CONTRACT TOTALS														
													\$34,508.65	\$1,764.25
OVERALL PROJECT TOTAL														
													\$201,587.62	\$3,681.19
													\$205,268.81	\$1,915.43

1) Item Not Used per Change Order No. 3  
 2) Item Not Used per Change Order No. 3  
 3) Overlay Tonnage Overrun and Paving Underman due to errors re existing full depth patches  
 4) Item Not Used



A	B	C	D		E		F	G	H		I	J	K	L	M	N	O	P
			UNITS	QTY	UNIT PRICE	CONTRACT PRICE			TOTALS AMOUNT PREVIOUS APPLICATION	AMOUNT THIS PERIOD								
6.01	ADJUSTMENT OF EXISTING MANHOLE AND CONCRETE BOXOUT, MINOR	EA	1		\$2,700.00	\$2,700.00		1	\$2,700.00	0	\$0.00	\$0.00		\$2,700.00	100%	\$0.00	\$0.00	\$155.00
7.01-1	HMA MILLING, 2 INCH	SY	1,285		\$4.20	\$5,394.00		0	\$0.00	0	\$0.00	\$0.00		\$0.00	0%	\$0.00	\$0.00	\$0.00
7.01-2	HMA OVERLAY, 3 INCH	TONS	120		\$82.00	\$9,840.00		120	\$11,240.00	0	\$0.00	\$0.00		\$11,240.00	100%	\$0.00	\$0.00	\$0.00
7.01-3	HMA PATCHES, FULL-DEPTH	SY	245		\$62.00	\$15,290.00		0	\$0.00	0	\$0.00	\$0.00		\$0.00	0%	\$0.00	\$0.00	\$0.00
7.01-4	POC CURB AND GUTTER, 3/8 INCH WIDE	LF	363		\$18,114.00	\$6,583.47		363	\$18,114.00	0	\$0.00	\$0.00		\$18,114.00	100%	\$0.00	\$0.00	\$0.00
7.01-5	REMOVAL OF EXISTING POC CURB AND GUTTER	LF	363		\$18,114.00	\$6,583.47		363	\$18,114.00	0	\$0.00	\$0.00		\$18,114.00	100%	\$0.00	\$0.00	\$0.00
7.01-6	POC DRIVEWAY PATCHES, FULL-DEPTH	SY	50		\$68.00	\$3,400.00		50	\$68,000.00	0	\$0.00	\$0.00		\$68,000.00	100%	\$0.00	\$0.00	\$0.00
7.01-7	REMOVAL OF EXISTING POC DRIVEWAY	SY	50		\$21.00	\$1,050.00		50	\$1,050.00	0	\$0.00	\$0.00		\$1,050.00	100%	\$0.00	\$0.00	\$0.00
7.01-8	TRAFFIC CONTROL	LS	1		\$2,000.00	\$2,000.00		1	\$2,000.00	0	\$0.00	\$0.00		\$2,000.00	100%	\$0.00	\$0.00	\$0.00
7.01-9	MOBILIZATION	LS	1		\$4,000.00	\$4,000.00		1	\$4,000.00	0	\$0.00	\$0.00		\$4,000.00	100%	\$0.00	\$0.00	\$0.00
8.01	ADJUSTMENT OF EXISTING MANHOLE AND CONCRETE BOXOUT, MINOR	EA	2		\$2,700.00	\$5,400.00		2	\$5,400.00	0	\$0.00	\$0.00		\$5,400.00	100%	\$0.00	\$0.00	\$0.00
7.01-10	HMA MILLING, 2 INCH	SY	2,690		\$4.20	\$11,394.00		2,690	\$11,394.00	0	\$0.00	\$0.00		\$11,394.00	100%	\$0.00	\$0.00	\$0.00
7.01-11	HMA OVERLAY, 3 INCH	TONS	340		\$82.00	\$28,080.00		340	\$28,080.00	0	\$0.00	\$0.00		\$28,080.00	100%	\$0.00	\$0.00	\$0.00
7.01-12	HMA PATCHES, FULL-DEPTH	SY	480		\$17.00	\$8,160.00		480	\$8,160.00	0	\$0.00	\$0.00		\$8,160.00	100%	\$0.00	\$0.00	\$0.00
7.01-13	POC CURB AND GUTTER, 3/8 INCH WIDE	LF	360		\$3,000.00	\$1,080.00		360	\$3,000.00	0	\$0.00	\$0.00		\$3,000.00	100%	\$0.00	\$0.00	\$0.00
7.01-14	REMOVAL OF EXISTING POC CURB AND GUTTER	LF	360		\$13,000.00	\$4,680.00		360	\$13,000.00	0	\$0.00	\$0.00		\$4,680.00	100%	\$0.00	\$0.00	\$0.00
8.02	TRAFFIC CONTROL	LS	1		\$2,145.00	\$2,145.00		1	\$2,145.00	0	\$0.00	\$0.00		\$2,145.00	100%	\$0.00	\$0.00	\$0.00
8.03	PAVEMENT MAINTENANCE	LS	1		\$0,000.00	\$0,000.00		1	\$0,000.00	0	\$0.00	\$0.00		\$0,000.00	100%	\$0.00	\$0.00	\$0.00
11.02	MOBILIZATION	LS	1		\$197,484.00	\$197,484.00		1	\$197,484.00	0	\$0.00	\$0.00		\$197,484.00	65%	\$64,684.77	\$0.00	\$1,128.48
ORIGINAL CONTRACT TOTALS																		

Change Order No. 1	Change Order No. 2 (Park and Cedar Pkds)	Change Order No. 3 (20m Avenue Overlay Adjustments)
CO1-1	GRANULAR SHOULDERS, TYPE B	7.01-1
CO1-2	CLEANING AND PREPARATION OF BASE	7.01-2
CO1-3	PAVEMENT SCARIFICATION	7.01-3
CO1-4	HMA BT INTERMEDIATE COURSE, 1/2 IN. MIX	7.01-4
CO1-5	HMA BT SURFACE COURSE, 1/2 IN. MIX, NO SPECIAL FRICTION	7.01-5
CO1-6	ASPHALT SANDER, PG 4-22B, STANDARD TRAFFIC	7.01-6
CO1-7	PAINTED PAVEMENT MARKINGS, WATERBORNE/ROLLENT	7.01-7
CO1-8	TRAFFIC CONTROL	7.01-8
CO1-9	FLAGGER	7.01-9
CO1-10	PILOT CAR	7.01-10
CO1-11	MOBILIZATION	7.01-11
CHANGE ORDER 1 CONTRACT TOTALS		
CHANGE ORDER 2 CONTRACT TOTALS		
CHANGE ORDER 3 CONTRACT TOTALS		
OVERALL PROJECT TOTAL		

Change Order No. 1	Change Order No. 2 (Park and Cedar Pkds)	Change Order No. 3 (20m Avenue Overlay Adjustments)
CO1-1	GRANULAR SHOULDERS, TYPE B	7.01-1
CO1-2	CLEANING AND PREPARATION OF BASE	7.01-2
CO1-3	PAVEMENT SCARIFICATION	7.01-3
CO1-4	HMA BT INTERMEDIATE COURSE, 1/2 IN. MIX	7.01-4
CO1-5	HMA BT SURFACE COURSE, 1/2 IN. MIX, NO SPECIAL FRICTION	7.01-5
CO1-6	ASPHALT SANDER, PG 4-22B, STANDARD TRAFFIC	7.01-6
CO1-7	PAINTED PAVEMENT MARKINGS, WATERBORNE/ROLLENT	7.01-7
CO1-8	TRAFFIC CONTROL	7.01-8
CO1-9	FLAGGER	7.01-9
CO1-10	PILOT CAR	7.01-10
CO1-11	MOBILIZATION	7.01-11
CHANGE ORDER 1 CONTRACT TOTALS		
CHANGE ORDER 2 CONTRACT TOTALS		
CHANGE ORDER 3 CONTRACT TOTALS		
OVERALL PROJECT TOTAL		

1 Item Not Used per Change Order No. 3  
 2 Item Not Used per Change Order No. 3  
 3 Overlay Tonnage Overrun and Patching Underrun due to areas no needing full depth patches  
 4 Item Not Used

# Change Order

## No. 3

Date of Issuance: 12/2/2021 Effective Date: 11/16/2021

Project: Story City North Park Phase 3 Improvements	Owner: City of Story City	Owner's Contract No.:
Contract: Story City North Park Phase 3 Improvements		Date of Contract: 05/17/2021
Contractor: Caliber Concrete, LLC		Engineer's Project No.: 08989015

**The Contract Documents are modified as follows upon execution of this Change Order:**

Description:

Work as identified in RFP #2.

**Attachments (list documents supporting change):**

Pricing email from Contractor.

RFP #2 identifying work to be completed.

**CHANGE IN CONTRACT PRICE:**

**CHANGE IN CONTRACT TIMES:**

Original Contract Price:

\$350,795.99

Original Contract Times:

Working days

Calendar days

Substantial completion (days or date): April 1, 2022

Ready for final payment (days or date): May 1, 2022

[Increase] [Decrease] from previously approved Change Orders No. 1 to No. 2

\$2,299.50

[Increase] [Decrease] from previously approved Change Orders No. \_\_\_\_\_ to No. \_\_\_\_\_

Substantial completion (days): \_\_\_\_\_

Ready for final payment (days): \_\_\_\_\_

Contract Price prior to this Change Order:

\$349,025.49

Contract Times prior to this Change Order:

Substantial completion (days or date): April 1, 2022

Ready for final payment (days or date): May 1, 2022

[Increase] [Decrease] of this Change Order:

\$31,503.77

[Increase] [Decrease] of this Change Order:

Substantial completion (days or date): \_\_\_\_\_

Ready for final payment (days or date): \_\_\_\_\_

Contract Price incorporating this Change Order:

\$380,529.26

Contract Times with all approved Change Orders:

Substantial completion (days or date): April 1, 2022

Ready for final payment (days or date): May 1, 2022

RECOMMENDED:

By: [Signature]  
Engineer (Authorized Signature)

Date: 12/02/2021

Approved by Funding Agency (if applicable): \_\_\_\_\_

ACCEPTED:

By: \_\_\_\_\_  
Owner (Authorized Signature)

Date: \_\_\_\_\_

ACCEPTED:

By: [Signature]  
Contractor (Authorized Signature)

Date: 12/2/21

Date: \_\_\_\_\_

**RE: Story City Park RFP #2 - Electrical & Slab for Water**

jasonmartin@caliber-concrete.com

**Sent:** 10/15/2021 10:59:44 AM

**To:** Andrew Inhelder; Rick McCarty; Jason Gettler (Caliber Concrete); Richard Hammons (Caliber Concrete)

**Folder:** \\msa-ps.com\fs\projects\8900s\8980s\8989\08989015\Email

---

Andrew

Van Mannen \$26794.65

Caliber 75 square feet sidewalk \$ 549.00

P and O \$ 2,734.37

Bond \$ 601.00

TOTAL \$30,679.02

----- Original Message -----

Subject: RE: Story City Park RFP #2 - Electrical & Slab for Water

From: Andrew Inhelder <ainhelder@msa-ps.com <mailto:ainhelder@msa-ps.com> >

Date: Thu, September 30, 2021 9:53 pm

To: Rick McCarty <rmccarty@vanmaanenelectric.com <mailto:rmccarty@vanmaanenelectric.com> >, Jason Martin (Caliber

Concrete) <jasonmartin@caliber-concrete.com <mailto:jasonmartin@caliber-concrete.com> >, Jason Gettler (Caliber

Concrete) <jasongettler@caliber-concrete.com <mailto:jasongettler@caliber-concrete.com> >, Richard Hammons (Caliber

Concrete) <richardhammons@caliber-concrete.com <mailto:richardhammons@caliber-concrete.com> >

Attached is an RFP for the electrical work and slab for the water service we discussed in the field. Please let me know what questions you have as you go through this.

Thanks,  
Andrew

#08989015

Andrew Inhelder, PE | Project Engineer  
MSA Professional Services, Inc.  
100% Employee Owned  
+1 (515) 635-3403

11/17/2021

## Andrew Inhelder

---

**From:** Josh Hetzler <jhetzler@vanmaanenelectric.com>  
**Sent:** Thursday, December 2, 2021 6:51 AM  
**To:** Andrew Inhelder  
**Cc:** Richard Hammons (Caliber Concrete); Jason Martin (Caliber Concrete); Jason Gettler (Caliber Concrete)  
**Subject:** RE: Story City Park RFP #2 - Electrical & Slab for Water

**Follow Up Flag:** Follow up  
**Flag Status:** Flagged

Andrew,

I sent this to Caliber on 10/11 – Approval came back on 11/16 – I cut a PO the following week and now our pole supplier (Sternberg) is saying there was a price increase with the timing. They had a 20-25 percent increase and I was able to get them to a 4.75 percent increase. Which is \$ 824.75 additional. I was afraid this could happen. How do you want to handle this one? Please let me know.

Thank you,

**Josh Hetzler**  
Vice President of Pre-Construction  
641-780-6154 Cell  
641-791-9473 Office

*Van Maanen*  

---

*Electric Inc.*



# PROPOSAL REQUEST

---

<b>CONTRACTOR:</b> <i>(Name and Address)</i>	Caliber Concrete, LLC 309 Audubon St Adair, IA 50002	<b>PROPOSAL REQUEST NO.:</b>	2
		<b>DATE OF ISSUANCE:</b>	09/30/2021
<b>OWNER:</b> <i>(Name and Address)</i>	City of Story City 504 Broad Street Story City, IA 50248	<b>CONTRACT FOR:</b>	Construction
		<b>CONTRACT DATED:</b>	May 17, 2021
<b>PROJECT:</b>	Story City North Park Phase 3 Improvements	<b>ENGINEER'S PROJECT NO.:</b>	08989015
		<b>ENGINEER:</b> <i>(Name and Address)</i>	MSA Professional Services, Inc. 1555 SE Delaware Ave Suite F Ankeny, IA 50021 1 (515) 964-1920

---

Please submit an itemized proposal for changes in the Contract Sum and Contract Time for proposed modifications to the Contract Documents described herein. Submit proposal within 10 days, or notify the Engineer in writing of the date on which you anticipate submitting your proposal.

THIS IS NOT A CHANGE ORDER, A CONSTRUCTION CHANGE DIRECTIVE OR A DIRECTION TO PROCEED WITH THE WORK DESCRIBED IN THE PROPOSED MODIFICATIONS.

Description: *(Insert a written description of the work.)*

Install buried electrical service from existing service to new light pole and outlets. Install two (2) new light poles and foundations with outlets. Refer to attachment for additional information.

Install 5'x5' concrete pad around water service stubbed out of ground. Water service to be installed by Owner. Connect 5'x5' concrete pad to adjacent sidewalk.

---

Attachments: *(List attached documents that support description.)*

Exhibit showing locations.

Cut sheets of selected poles, fixtures, arms, outlets, covers, boxes.

---

REQUESTED BY: MSA Professional Services, Inc.

---

Andrew Inhelder, PE

cc:



Point #	Raw Description	Elevation	Method	Ending
1*	CP-SPHCE	880.987	3638886.93	4889817.88
2*	CP-SPHCE	873.819	3637330.88	4889827.95
3	CP-SPHCE	873.824	3637365.88	4889818.84
3*	EP-TELEP	873.189	3637364.87	4889818.88
4	EP-TELEP	867.884	3637388.24	4889888.11
16	EA-TELEP	873.528	3637479.88	4889768.88
17	CP-SPHCE	876.534	3637388.28	4889767.63
18	CP-SPHCE	871.896	3637388.28	4889767.63
19	CP-SPHCE	871.988	3637394.31	4889764.34
211*	BM-18 SPH41	879.988	3637395.15	4889888.51

DDNOTES POINT 6 OFF PAGE

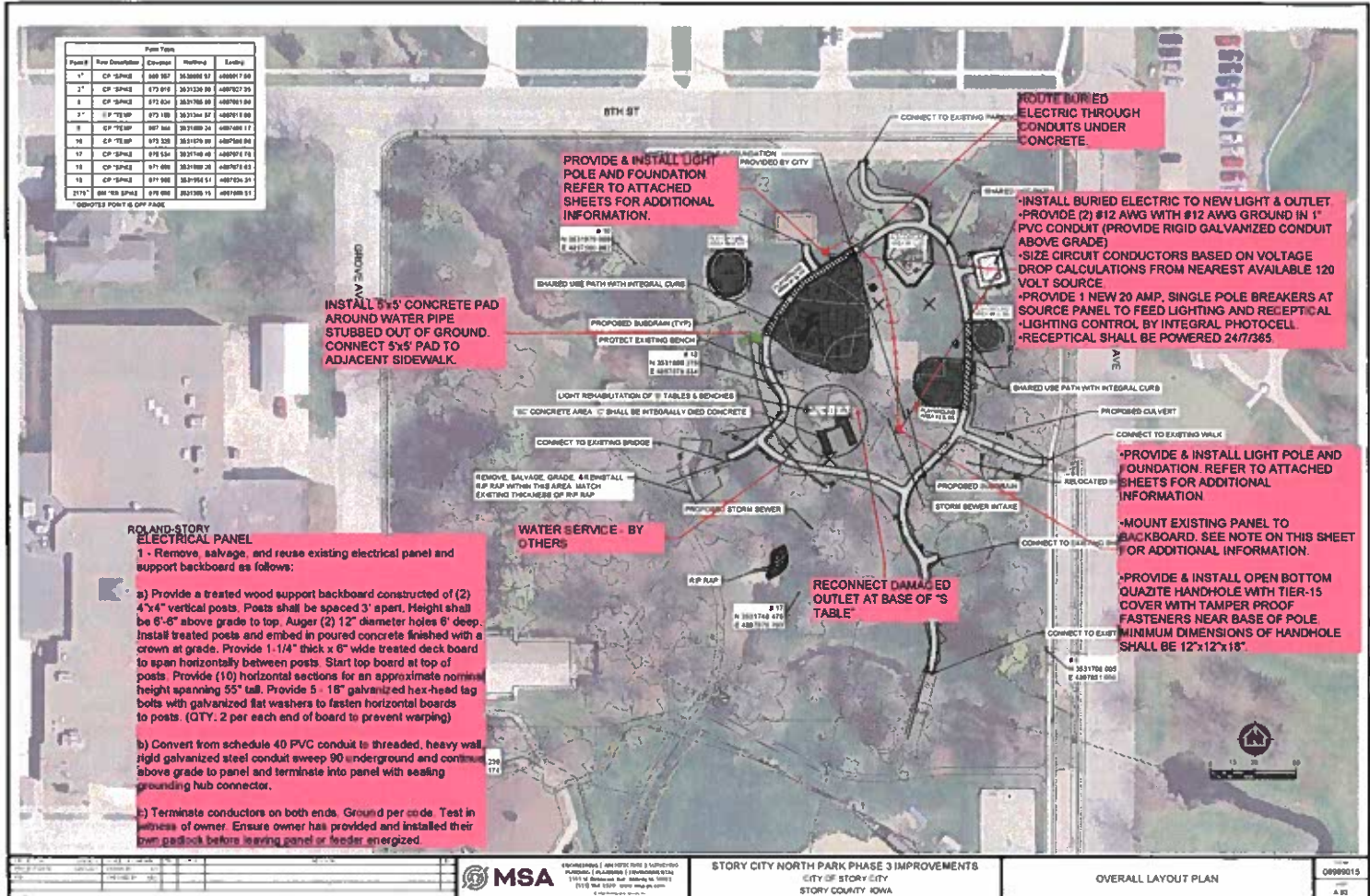

**INSTALL 5x5' CONCRETE PAD AROUND WATER PIPE STUBBED OUT OF GROUND. CONNECT 5x5' PAD TO ADJACENT SIDEWALK.**

**PROVIDE & INSTALL LIGHT POLE AND FOUNDATION. REFER TO ATTACHED SHEETS FOR ADDITIONAL INFORMATION.**

**ROUTE BURIED ELECTRIC THROUGH CONDUITS UNDER CONCRETE.**

**INSTALL BURIED ELECTRIC TO NEW LIGHT & OUTLET.**  
 - PROVIDE (2) #12 AWG WITH #12 AWG GROUND IN 1" PVC CONDUIT (PROVIDE RIGID GALVANIZED CONDUIT ABOVE GRADE)  
 - SIZE CIRCUIT CONDUCTORS BASED ON VOLTAGE DROP CALCULATIONS FROM NEAREST AVAILABLE 120 VOLT SOURCE  
 - PROVIDE 1 NEW 20 AMP. SINGLE POLE BREAKERS AT SOURCE PANEL TO FEED LIGHTING AND RECEPTICAL  
 - LIGHTING CONTROL BY INTEGRAL PHOTOCELL  
 - RECEPTICAL SHALL BE POWERED 24/7/365.

**20-STOREY ELECTRICAL PANEL**  
 1 - Remove, salvage, and reuse existing electrical panel and support backboard as follows:

- Provide a treated wood support backboard constructed of (2) 4"x4" vertical posts. Posts shall be spaced 3' apart. Height shall be 6'-6" above grade to top. Auger (2) 12" diameter holes 6" deep. Install treated posts and embed in poured concrete finished with a crown at grade. Provide 1-1/4" thick x 6" wide treated deck board to span horizontally between posts. Start top board at top of posts. Provide (10) horizontal sections for an approximate nominal height spanning 55" tall. Provide 5 - 1/8" galvanized hex-head lag bolts with galvanized flat washers to fasten horizontal boards to posts. (QTY. 2 per each end of board to prevent warping)
- Convert from schedule 40 PVC conduit to threaded, heavy wall rigid galvanized steel conduit sweep 90° underground and continue above grade to panel and terminate into panel with sealing grounding hub connector.
- Terminate conductors on both ends. Ground per code. Test in witness of owner. Ensure owner has provided and installed their own padlock before leaving panel or feeder energized.

**WATER SERVICE - BY OTHERS**

**RECONNECT DAMAGED OUTLET AT BASE OF 'S' TABLE**

**PROVIDE & INSTALL LIGHT POLE AND FOUNDATION. REFER TO ATTACHED SHEETS FOR ADDITIONAL INFORMATION.**

**MOUNT EXISTING PANEL TO BACKBOARD. SEE NOTE ON THIS SHEET FOR ADDITIONAL INFORMATION.**

**PROVIDE & INSTALL OPEN BOTTOM QUARTZITE HANDHOLE WITH TIER-15 COVER WITH TAMPER PROOF FASTENERS NEAR BASE OF POLE. MINIMUM DIMENSIONS OF HANDHOLE SHALL BE 12"x12"x18".**

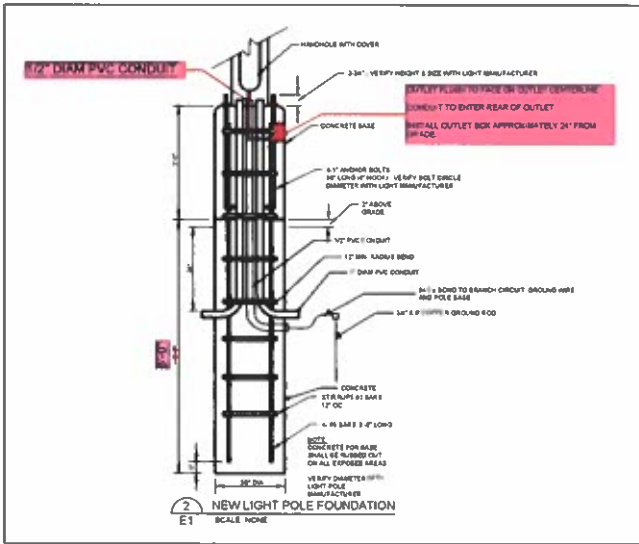

**9700 BIRMINGHAM ROADWAY 6" to 8" Diameters**

**SPECIFICATIONS**

**GENERAL**

The 23 ft tall decorative post shall be aluminum or steel, one piece construction. The post shall have a cast aluminum, decorative two-piece split base that clamps around the pole and base plate. The 24" diameter x 60" tall cover shall have one access door.

**CONSTRUCTION**

The base shall be designed with a tall, smoothly curved pedestal bottom section and transition to a tall twelve flute vertical base section with a large access door. It shall be made of heavy wall, 356 alloy cast aluminum. **Indicate the type of shaft needed.**

The round tapered fluted shaft shall be made of ASTM A572 grade 50, high-strength structural steel or ASTM 6063T6 aluminum.

\_\_\_ The round tapered smooth shaft shall be made of ASTM 6063T6 extruded aluminum and tempered to a T6 condition or ASTM A572 steel.

\_\_\_ The round straight fluted shaft shall be made of ASTM A595 grade A, high-strength structural steel or ASTM 6061T6 aluminum.

\_\_\_ The round straight smooth shaft shall be made of ASTM 6061T6 extruded aluminum and tempered to a T6 condition or ASTM A572 steel. It shall have a decorative fluted tenon.

\_\_\_ The octagonal tapered shaft shall be made of ASTM A607 high-strength, tapered structural steel.

**INSTALLATION**

The cast aluminum fluted base cover shall clamp around the base plate and lower shaft of the pole assembly. It shall be clamped together using tamper-proof stainless steel screws. An access door shall be provided in the pole shaft and in the cast aluminum fluted base cover for wiring and mechanically secured with tamper-proof, stainless steel screws.

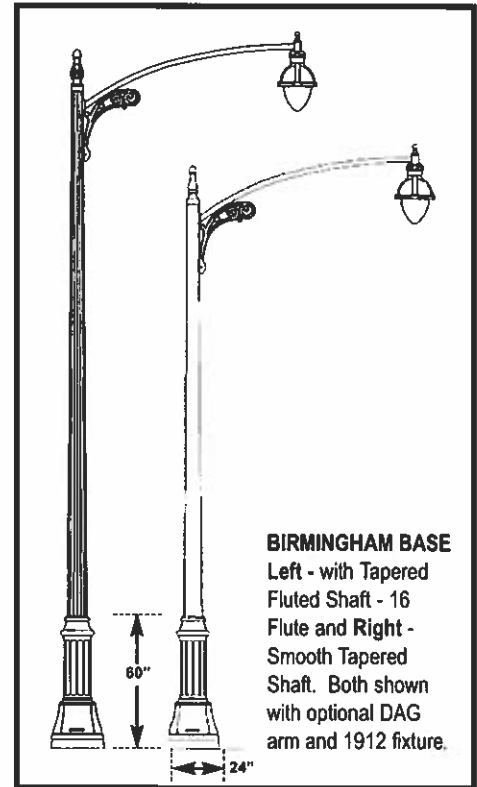

**BIRMINGHAM BASE**  
Left - with Tapered Fluted Shaft - 16 Flute and Right - Smooth Tapered Shaft. Both shown with optional DAG arm and 1912 fixture.

**Roadway Arms Available for 9700 Birmingham Series**

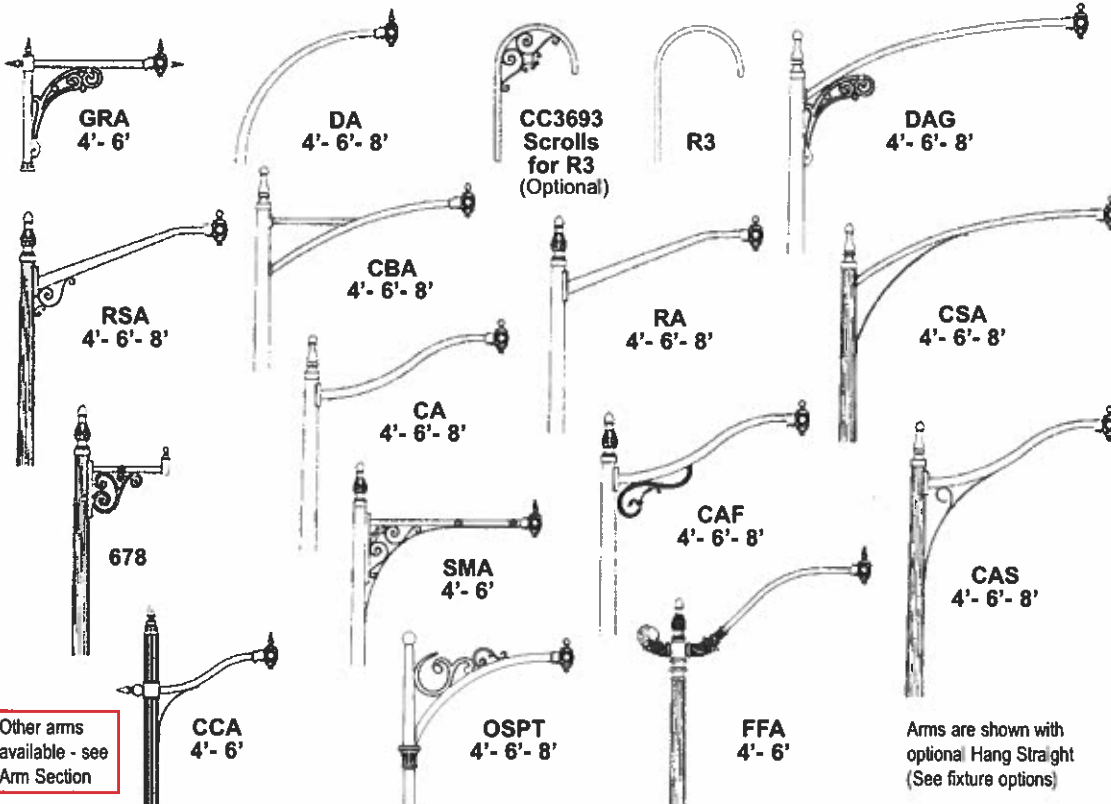

**POLE HEIGHT CALCULATOR**

Add distance listed below to desired mounting height of fixture to calculate pole height needed.

ARM	
CAS	-2'
CA	-1'
CAF	-1'
CSA	-2'
RA	-1'
RSA	-1'
DAG	-2'
SMA	+1'
GRA	-3'
CCA	+1'
CBA	0
DA	-7'
R3	-3'
FFA	-3'
OSPT	-3'
678	0

Other arms available - see Arm Section

Arms are shown with optional Hang Straight (See fixture options)



**9700 BIRMINGHAM ROADWAY 6" to 8" Diameters POSTS / OPTIONS / POST CAPS**

**BUILDING A PART NUMBER**

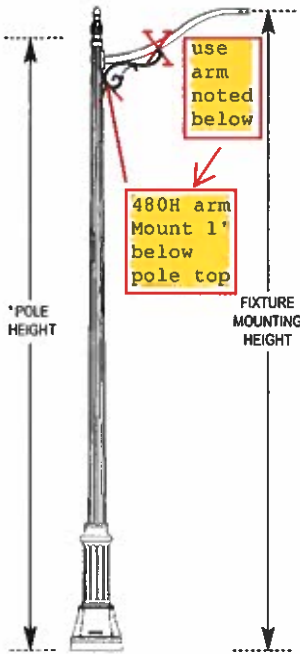

MODEL	*POLE HEIGHT	SHAFT MATERIAL	SHAFT STYLE	FLUTED SHAPE (If Applicable)	POST CAP CENTER	OPTIONS	FINISH
97	25	S	RTF		RDBP		BK

**Part Number Selections**

MODEL	*POLE HEIGHT	SHAFT MATERIAL	SHAFT SHAPE	FLUTED SHAPE (If Applicable)	SHAFT TYPE (Pole Shapes)
97	20', 23', 25', 30', 32', 35', 40'	S-Steel, A-Aluminum, G-Galvanized	RTF - Round Tapered Fluted, RTS - Round Tapered Smooth, RSF - Round Straight Fluted, RSS - Round Straight Smooth, OTS** - Octagonal Tapered Smooth	16FF, 16SF, 12FF, 12SF, 8SF	16-Sharp Flute, 16-Flat Flute, 12-Flat Flute, Round, 8-Sharp Flute, Octagonal

Shaft diameters and wall thickness will be determined by the factory, based on desired pole design with selected options and basic wind velocity (Referenced by AASHTO). Check your local area for wind speed or any other structural requirements.

\*Use Pole Height Calculator to determine pole height based on desired mounting height of fixture.

All Tapered Shafts have a taper of 0.14 inch per foot of length, most shafts are available in steel and/or aluminum.

**OPTIONS AVAILABLE**

See Accessories Section for more options and information

<b>GFI</b> - Ground Fault Interrupter mounts in the pole <b>FH</b> - Flag Pole Holder mounts on the pole <b>HS-B</b> Hang Straight Ball <b>HS-F</b> Hang Straight Finial	<b>SBA</b> - Single Banner Arm mounts on the pole <b>DBA</b> - Double Banner Arms mount on same side of the pole <b>SBAR</b> -Single Banner Arm and Ring <b>DSPA</b> -Double Stepped Planter Arms mount on either side <b>DHPA</b> -Double Hooked Planter Arms mount on either side <b>PA478</b> -Decorative Planter Arms with planter rings	<b>PCD</b> - Photo Control mounts on door on pole <b>SH</b> - Speaker Hub for mounting speaker, floodlight or signal <b>SB</b> - Sign Bracket mounts on pole to hold signs <b>WHK</b> - Wreath Hook mounts on pole to hold decorations
---	---	---

**POST CENTER CAPS (If Required)**

Color by Owner

**POST CENTER CAP**

RC	RBCC3	RSSCC	RSB4
RSB5	RPBP	RDBP	

- OPTIONS AVAILABLE (Above)**
- GFI
  - FH
  - SBA
  - DBA
  - DB Direct Burial
  - SBAR
  - DSPA
  - DHPA
  - PA478
  - HB Helix Burial
  - PCD
  - SH
  - SB
  - WHK

- STANDARD FINISHES\***
- BKT Black Textured
  - WHI White Textured
  - PGT Park Green Textured
  - ABZT Architectural Medium Bronze Textured
  - DBT Dark Bronze Textured
- \*Smooth Finishes are available upon request
- CUSTOM FINISHES**
- OI Old Iron

- RT Rust
  - WBR Weathered Brown
  - CD Cedar
  - WBK Weathered Black
  - TT Two Tone
- STERNBERG SELECT FINISHES**
- VG Verde Green
  - SI Swedish Iron
  - OWGT Old World Gray Textured

# 480 ARMS & WALL BRACKETS

The 480 arm includes a diverse family of sizes and orientations that allow for many mounting configurations that meet almost any project design requirements. These heavy cast arms look robust and substantial while still showing well-proportioned dimensions, scale and classic detailing. Matching well with traditional luminaires these arms can be pole or wall mounted in single or multiple head configurations.



BUILD A PART NUMBER		
ORDERING EXAMPLE: 480-PM-BKT		
Arm	Mounting Style	Finish
480H	PM	

## Arms

• 480 • **480H** • 480DH • 480LF • 480D  
 D=Down Sweeping H=Hanging LF=Long Font

## Mounting Styles

- **PM** Post Mount
- **WB** Wall Bracket
- **WBBB** Wall Bracket With Ballast Box

Mount 1' down from top of pole

## Finish (Click here to view paint finish sheet)

### Standard Finishes<sup>1</sup>

- **BKT** Black Textured
- **WHT** White Textured
- **PGT** Park Green Textured
- **ABZT** Architectural Medium Bronze Textured
- **DBT** Dark Bronze Textured

<sup>1</sup>Smooth finishes are available upon request.

### Custom Finishes<sup>2</sup>

- **CM** Custom Match
- **OI** Old Iron
- **RT** Rust
- **WBR** Weathered Brown
- **CD** Cedar

- **WBK** Weathered Black
- **TT** Two Tone

<sup>2</sup>Custom colors require upcharge.

### Sternberg Select Finishes

- **VG** Verde Green
- **SI** Swedish Iron
- **OWGT** Old World Gray Textured

## Arms

Cat. #	Detail	Dimension	Available Mounting Styles	Weight / EPA
480		17-3/4" L 15-1/4" H	PM WB WBBB	6.3 LBS 0.78 SQ FT
480H		17-3/4" L 18-3/8" H	<b>PM</b> WB WBBB	6.3 LBS 0.78 SQ FT
480DH		17-3/4" L 13-3/4" H	PM WB WBBB	6.3 LBS 0.78 SQ FT
480LF		17-3/4" L 15-1/4" H	PM WB WBBB	7.7 LBS 0.82 SQ FT
480D		17-3/4" W 18-3/4" H	PM WB WBBB	6.3 LBS 0.78 SQ FT

## Mounting Style

Mounting Style	Detail	Back Plate/ Rough in Dimensions	Extension	Fit
PM		2-1/2" W 13-3/4" H	17-3/4"	3" - 6" Poles
WB*		4-3/4" W 15-1/4" H	17-3/4"	Flat Wall
WBBB*		6" W 16-5/8" H	22-3/4"	Flat Wall

\*Click Mounting Style for installation instructions.

LED



# 1940LED Glenview 1950LED Mission Trails

EPA  
0.79 (ft<sup>2</sup>)  
0.83 (ft<sup>2</sup>)  
WEIGHT  
37 LBS  
34.5 LBS

7 YEAR  
WARRANTY

LUMEN  
RANGE  
18,050  
to 3,820

LUMEN  
MAINTENANCE  
L70  
MINIMUM  
100,000  
HOURS

UL  
LISTED

CLICK  
FOR FAQ'S

IP RATING

JOB NAME \_\_\_\_\_

FIXTURE TYPE \_\_\_\_\_

MEMO \_\_\_\_\_

## BUILD A PART NUMBER

ORDERING EXAMPLE: **2A-1940LED-IL40T5-MDL06-SG-FHD/478PM/3810FP4/BKT**

Mounting Config.	Fixture	LED	CCT	Type	Driver	Lens	Option Control Receptacle	Option Control	Option Fuse	Option Hangstraight	Option House Side Shield	Arm See Arm Spec Sheets	Pole See Pole Spec Sheets	Finish
1A	1950LED	2L	40(00)	T3	MDL10	SV2	----	PEC		----	----			

### Mounting Configuration

(Click here to view mounting configuration sheet)

- IW
- 1A
- 2A
- 2A90
- 3A
- 3A90
- 4A
- IAM
- 2AM
- SH44<sup>1</sup>
- CH44<sup>1</sup>
- CAT

W = Wall Mount A = Arm Mount AM = Arm Mid-Mount  
SH = Stem Hung CH = Chain Hung CAT = Catenary

<sup>1</sup> Include overall drop length in inches after designation for Stem/Chain application (IE: CH44-48").

### Fixture

- 1940LED
- 1950LED

### LED

- IL
- 2L

### CCT - Color Temperature (K)

- 27(00)
- 30(00)
- 35(00)
- 40(00)
- 50(00)

### Type

- T2
- T3
- T4
- T5

### Driver

- MDL06 (120V-277V, 600mA) (IL system only)
- MDH06 (347V-480V, 600mA)
- MDL08 (120V-277V, 800mA) (2L system only)
- MDH08 (347V-480V, 800mA)
- MDL09 (120V-277V, 900mA) (IL system only)
- MDH09 (347V-480V, 900mA)
- MDL10 (120V-277V, 1050mA) (2L system only)
- MDH10 (347V-480V, 1050mA)
- MDL12 (120V-277V, 1200mA) (IL or 2L system)
- MDH12 (347V-480V, 1200mA)
- MDL14 (120V-277V, 1400mA) (2L system)
- MDH14 (347V-480V, 1400mA)

### Lens

- SG (Sag Glass)
- FSG (Frosted Sag Glass)
- FG (Flat Glass)
- FFG (Frosted Flat Glass)
- SV1 (Flat Acrylic)
- SV2 (Flat Acrylic)

### Options (Click here to view accessories sheet)

- R7<sup>2</sup> 7-Pin Control Receptacle Only
- PE<sup>3</sup> Twist-Lock Photocontrol (120V-277V)
- PE4<sup>3</sup> Twist-Lock Photocontrol (347V-480V)
- SC<sup>3</sup> Shorting Cap
- PEC Electronic Button Photocontrol (120V-277V)
- PEC4 Electronic Button Photocontrol (480V)
- FHD<sup>4</sup> Double Fuse and Holder
- HSHS Standard Horizontal Hangstraight, Spike Finial
- HSHN Standard Horizontal Hangstraight, No Finial
- HSHB Standard Horizontal Hangstraight, Ball Finial
- EZ Vertical Hangstraight, Large, "EZ" Mount
- HSS 120° House Side Shield

<sup>2</sup> Only available with HSH.

<sup>3</sup> Requires control receptacle.

<sup>4</sup> Ships loose for installation in base.

### Arm (Click here to view arm website page)

See Arms & Wall Brackets specification sheets.

- 478
- 480
- 1080
- 1082
- 1085
- 1087
- R2<sup>5</sup>

<sup>5</sup> Luminaires above grade height to be 2' higher than pole height, REQUIRES "EZ" hangstraight.

### Pole (Click here to view pole website page)

See Pole specification sheets.

### Finish (Click here to view paint finish sheet)

#### Standard Finishes<sup>6</sup>

- BKT Black Textured
- WHT White Textured
- PGT Park Green Textured
- ABZT Architectural Medium Bronze Textured
- DBT Dark Bronze Textured

<sup>6</sup> Smooth finishes are available upon request.

#### Custom Finishes<sup>7</sup>

- CM Custom Match
- OI Old Iron
- RT Rust
- WBR Weathered Brown
- CD Cedar
- WBK Weathered Black
- TT Two Tone

<sup>7</sup> Custom colors require upcharge.

### Sternberg Select Finishes

- VG Verde Green
- SI Swedish Iron
- OWGT Old World Gray Textured

## Specifications

### Fixture

The 1940/1950 series is a decorative pendant luminaire which consists of a decorative cast aluminum fitter, and heavy gauge spun aluminum shade with integral lens frame and tool-less latch mechanism. The optical enclosure is sealed against moisture and dust penetration, IP66 rated per IEC 60598. The luminaire shall be UL listed in US and Canada.

### LEDs

The luminaire shall use high output, high brightness COB LEDs. The LEDs are mounted to maximize thermal transfer to the heat sink surface. The LEDs shall be 100% recyclable; not contain lead, mercury or any other hazardous substances and shall be RoHS compliant. The LEDs shall be roof mounted to minimize up-light. Lumen maintenance shall be determined in accordance with IESNA TM-21, based on LED manufacturer LM-80 test data of no less than 6,000 hours and in-situ testing of the luminaire by an NVLAP accredited Energy Efficient Lighting Products lab. The high-performance white LEDs will have a predicted lumen depreciation of approximately 100,000 hours with greater than 70% of initial output at 25°C. The high-brightness, high-output white LEDs shall be 4000K nominal (2700K, 3000K, 3500K or 5000K optional) correlated color temperature (CCT) with a 70 (minimum) color rendering index (CRI). Consult factory for custom CCT or CRI. The luminaire shall have a minimum \_\_\_\_\_ (see table) delivered initial lumens when operated at steady state with an average ambient temperature of 25°C (77°F).

### Optics

The luminaire shall be provided with individual, refractor type optics applied to each LED. The luminaire shall provide Type \_\_\_\_ (2, 3, 4 or 5)

See next page

**SternbergLighting**  
ESTABLISHED 1923 / EMPLOYEE OWNED

800-621-3376  
555 Lawrence Ave., Roselle, IL 60172  
contactus@sternberglighting.com  
www.sternberglighting.com

421 STERNBERG LIGHTING ALL RIGHTS RESERVED. PRINTED IN THE USA

# 1940LED Glenview / 1950LED Mission Trails



<p>light distribution per the IESNA classifications. Testing shall be done in accordance with IESNA LM-79.</p> <p><b>Electronic Driver</b> The LED driver shall be U.L. Recognized. It shall be securely mounted inside the fixture, for optimized performance and longevity. It shall be supplied with a quick-disconnect electrical connector on the power supply, providing easy power connections and fixture installation. It shall have overload, overheat and short circuit protection, and have a DC voltage output, constant current design, 50/60HZ. It shall be supplied with line-ground, line-neutral and neutral-ground electrical surge protection in accordance with IEEE/ANSI C62.41.2 guidelines. It shall be a high efficiency driver with a THD less than 20% and a high power factor greater than .9. It shall be dimming capable using a 0-10v signal, consult factory for more information.</p>	<p><b>Lens</b> Materials include Glass, Acrylic or Polycarbonate.</p> <p><b>Photocontrols</b> <b>Button Style:</b> On a single assembly the photocontrol shall be mounted on the fixture and pre-wired to driver. On multiple head assembly's the photocontrol shall be mounted in the pole shaft on an access plate. The electronic button type photocontrol is instant on with a 5-10 second turn off, and shall turn on at 1.5 footcandles with a turn-off at 2-3 footcandles. Photocontrol is 120-277 volt and warranted for 6 years. <b>Twist-Lock Style:</b> The photocontrol shall be mounted on the hang-straight and pre-wired to driver. The twist lock type photocontrol is instant on with a 3-6 second turn off, and shall turn on at 1.5 footcandles with a turn-off at 2-3 footcandles. Photocontrol is 120-277 volt and warranted for 6 years.</p>	<p><b>Warranty</b> Seven-year limited warranty. See product and finish warranty guide for details.</p> <p><b>Finish</b> Refer to website for details.</p>
--	--	---

## Performance - 1940LED/1950LED

MODEL #	T2 LUMENS	BUG	EFFICACY (LPW)	T3 LUMENS	BUG	EFFICACY (LPW)	T4 LUMENS	BUG	EFFICACY (LPW)	T5 LUMENS	BUG	EFFICACY (LPW)	WATTS
2L40T_-MDL14	17445	B3U0G3	111.8	17370	B3U0G3	111.3	17580	B3U0G2	112.7	18050	B4U0G2	115.7	156
2L30T_-MDL14	17000	B3U0G3	109.0	16925	B3U0G3	108.5	17130	B3U0G2	109.8	17590	B4U0G2	112.8	156
2L27T_-MDL14	15445	B3U0G3	99.0	15380	B3U0G3	98.6	15565	B3U0G2	99.8	15980	B4U0G2	102.4	156
2L40T_-MDL12	15370	B3U0G3	115.6	15275	B3U0G3	114.8	15505	B3U0G2	116.6	15880	B4U0G2	119.4	133
2L30T_-MDL12	14980	B3U0G3	112.6	14885	B3U0G3	111.9	15110	B3U0G2	113.6	15475	B4U0G2	116.4	133
2L27T_-MDL12	13610	B3U0G3	102.3	13525	B3U0G3	101.7	13725	B3U0G2	103.2	14060	B4U0G2	105.7	133
2L40T_-MDL10	13130	B3U0G3	118.3	13045	B3U0G3	117.5	13230	B3U0G2	119.2	13560	B3U0G2	122.2	111
2L30T_-MDL10	12795	B3U0G3	115.3	12715	B3U0G3	114.5	12895	B3U0G2	116.2	13215	B3U0G2	119.1	111
2L27T_-MDL10	11625	B3U0G3	104.7	11550	B3U0G3	104.1	11715	B3U0G2	105.5	12005	B3U0G2	108.2	111
2L40T_-MDL08	10700	B2U0G2	121.6	10655	B2U0G2	121.1	10805	B2U0G2	122.8	11065	B3U0G2	125.7	88
2L30T_-MDL08	10425	B2U0G2	118.5	10385	B2U0G2	118.0	10530	B2U0G2	119.7	10785	B3U0G2	122.6	88
2L27T_-MDL08	9475	B2U0G2	107.7	9435	B2U0G2	107.2	9565	B2U0G2	108.7	9795	B3U0G2	111.3	88
1L40T_-MDL12	7880	B2U0G2	112.6	7825	B2U0G2	111.8	7850	B2U0G1	112.1	8170	B3U0G1	116.7	70
1L30T_-MDL12	7680	B2U0G2	109.7	7625	B2U0G2	108.9	7650	B2U0G1	109.3	7960	B3U0G1	113.7	70
1L27T_-MDL12	6975	B2U0G2	99.6	6930	B2U0G2	99.0	6950	B2U0G1	99.3	7235	B3U0G1	103.4	70
1L40T_-MDL09	6400	B2U0G2	118.5	6345	B2U0G2	117.5	6370	B2U0G1	118.0	6630	B3U0G1	122.8	54
1L30T_-MDL09	6235	B2U0G2	115.5	6185	B2U0G2	114.5	6210	B2U0G1	115.0	6460	B3U0G1	119.6	54
1L27T_-MDL09	5665	B2U0G2	104.9	5620	B2U0G2	104.1	5640	B2U0G1	104.4	5870	B3U0G1	108.7	54
1L40T_-MDL06	4350	B1U0G1	120.8	4315	B1U0G1	119.9	4330	B1U0G1	120.3	4505	B2U0G1	125.1	36
1L30T_-MDL06	4240	B1U0G1	117.8	4205	B1U0G1	116.8	4220	B1U0G1	117.2	4390	B2U0G1	121.9	36
1L27T_-MDL06	3850	B1U0G1	106.9	3820	B1U0G1	106.1	3835	B1U0G1	106.5	3990	B2U0G1	110.8	36



800-621-3376  
555 Lawrence Ave., Roselle, IL 60172  
contactus@sternberglighting.com  
www.sternberglighting.com



# 1940LED Glenview / 1950LED Mission Trails

LED

## Fixtures

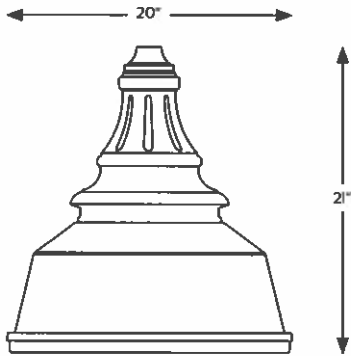

1940LED-FG

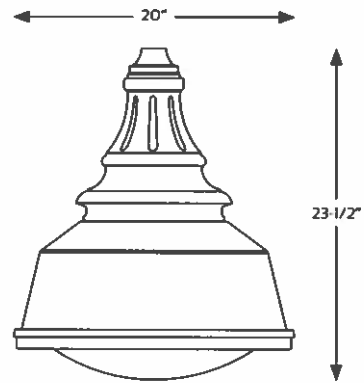

1940LED-SG

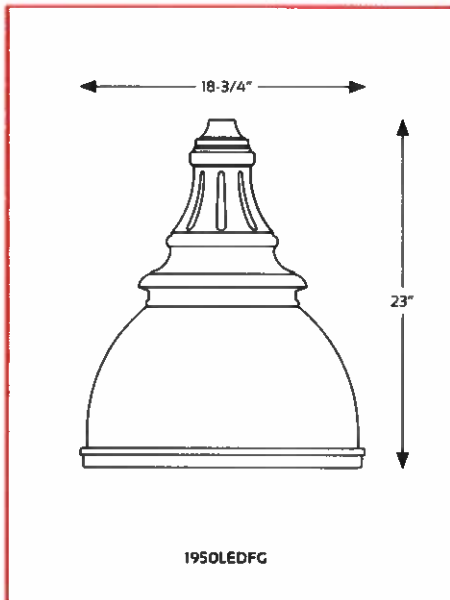

1950LED-FG

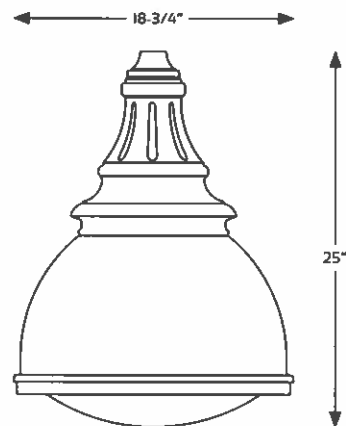

1950LED-SG



**SternbergLighting**  
ESTABLISHED 1923 / EMPLOYEE OWNED

800-621-3376  
555 Lawrence Ave., Roselle, IL 60172  
contactus@sternberglighting.com  
www.sternberglighting.com

4/21 STERNBERG LIGHTING. ALL RIGHTS RESERVED. PRINTED IN THE USA



## SINGLE GANG BOXES - 2 IN. TO 2-5/8 IN. DEEP

2 in. Deep with Lugs - Three Threaded Outlets - 4-1/2 in. x 2-3/4 in.  
N/A

D04



Catalog # 5320-0

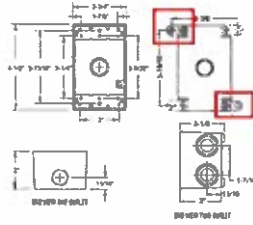

- Pour box flush on vertical center-line with face of round concrete pole base (mount at 24" AFG). Perfectly cut a rectangle into SONO-tube so that the sides of the box are allowed to slightly protrude enough so that center of box (top and bottom) is still flush with concrete face to accommodate the cover fitting flat on the box face when SONO-tube is removed. Use the mounting ears to help box "hold" in concrete pour and fasten box to re-bar. Provide 1/2" RGS conduit from center of box turned 90 degrees up into the pole base and finish with bushing in accessible hand hole for splicing to lighting circuit using #12 stranded copper conductors rated THHN/THWN 600V. Reference other sheets for "while in use - extra heavy duty lockable cover and for combo 20 amp GFCI/USB receptacle.

### APPLICATIONS

For use in branch circuit wiring in wet, damp, or dry locations  
May be used as a weatherproof junction box, or as a housing for receptacles, switches, and GFCI's

### PRODUCT FEATURES

- Reinforced connector outlets
- State-of-the-art powder coat finish provides maximum weatherability and scratch resistance
- Eight box mounting options with detachable lugs
- Two closure plugs included
- Hubs accept all threaded fittings and threaded conduit
- Ground screw installed
- Multi-lingual instructions in each package
- Includes gasket and mounting hardware
- N/A

### UL LISTED

File E195978

### CSA

C22.2 No. 18

### NEMA

3R Rated

### GENERAL PRODUCT INFORMATION

Color: Gray

### CONFIGURATION

Number Of Outlets: 3  
Gangs: 1

### PRODUCT MEASUREMENTS

Depth: 2 in  
Outlet Size: 1/2 in  
Cubic Inches (cm<sup>3</sup>): 18.3 (299.9)  
Wt. Ea (Lbs): 0.608

### PACKAGING

Package Type: Shrink  
Std. Pkg: 20  
Product UPC-A Labeled: Yes  
Ship Carton Length (in): 16.19  
Ship Carton Width (in): 6.50  
Ship Carton Height (in): 8.50  
Ctn Weight (Lbs): 13.33  
Pallet Qty: 1800.00  
UPC Number: 050169532003  
I2of5: 50050169532008



**Pass and Seymour**  
**radiant 20A Hospital Grade Tamper Resistant Self Test GFCI USB Type AC Outlet, Gray**  
**Part No. 2097HGTRUSBACGRY**



Temporarily Unavailable

Provide superior safety and the convenience of built-in USB charging, with this first-of-its-kind outlet. Perfect for adding modern connectivity anywhere desired, even in the areas of hospital and healthcare facilities where ground fault protection is required. This outlet makes it easy to see and reset electrical trips right where they happen, while also providing two USB connections for keeping phones or tablets charged, no bulky adapter necessary.

**Features & Benefits**

- First outlet of its kind to add USB connection to a GFCI outlet for easier charging anywhere. Rated for use in hospitals and healthcare facilities, this outlet offers superior durability and reliable ground fault protection. Includes a trip indicator light and reset button on the outlet for easy, accessible troubleshooting.
- Includes traditional power outlets, as well as one USB Type-A and one USB Type-C. Self-tests every three seconds, ensuring continuous ground fault protection for greater safety. Additionally, in case of test failure, the indicator light (red LED) will flash to signal there is an issue and the outlet should be replaced.
- Equipped with proven SafeLock™ feature which disconnects power to the outlet if any critical components are damaged for added protection. Prevents the insertion of foreign objects while maintaining a discreet, invisible effect with patented, black "invisible shutter" system. Meets NEC's Tamper-Resistant requirements.
- Installs quickly thanks to a redesigned side wire cavity for easier access. Can provide ground fault protection to downstream outlets through feed-thru wiring.

**Specifications**

**General Info**

Color	Gray	UPC Number	78300737762
Country Of Origin	China	Product Line	Pass & Seymour
Finish	Matte	Application Sector	Residential/Commercial
Type	GFCI, Duplex, Tamper Resistant, USB	Number of Receptacles	2
Warranty Type	1-Year Limited Warranty		

**Listing Agencies / 3rd Party Agencies**

cULus Listed	Yes	CSA Listed	Yes
CSA File Number	CSA C22.2 No. 223, CSA C22.2 No. 42	cULus ListingNumber	E113595

**Additional Information**

RoHS Compliant	Yes
----------------	-----

**Technical Information**

Wattage	1875 W	Number of Gangs	1
---------	--------	-----------------	---

---

Voltage	120 V	Mounting type	Box
Number of USBs	2	is Weather Resistant	No
Indoor/Outdoor	Indoor	is Tamper Resistant	Yes

---





## METALLIC LOW PROFILE WIU COVERS

Single Gang Metal Low Profile While-In-Use Covers - Extra Duty®  
Vertical 8-in-1

C11



Catalog # MX4280S



### APPLICATIONS

Designed for use whenever weatherproof protection is required while an outlet is in use.  
NA

### PRODUCT FEATURES

- Revolutionary patented design expands from 2" to 3-1/2" for while-in-use needs
- Heavy duty die-cast metal construction
- Patented Quick-Fit™ keyhole mounting system allows installation in under a minute
- Pre-configured for GFCI with patented Knockout technology for alternate devices
- Includes attached gasket and mounting hardware
- Lockable tab
- Premium Powder Coat

### UL LISTED

File E212332

### NEMA

3R Rated

### NEC

2014 Compliant (article 406 9A & B) Extra Duty Rated

### US PATENTS

8,314,334, 8,259,253 B1, 6,420,654, 8,106,295 B1

### GENERAL PRODUCT INFORMATION

Color: Gray

### CONFIGURATION

Gangs: 1

### PRODUCT MEASUREMENTS

Depth: 2 in. to 3-1/2 in.  
Wt. Ea. (Lbs.): 0.731

### PACKAGING

Package Type	Shrink
Std. Pkg.	6
Product UPC-A Labeled	Yes
Weight (Lbs. Per/C)	73.10
Ship Carton Length (in.)	14.61
Ship Carton Width (in.)	3.86
Ship Carton Height (in.)	7.08
Ctn Weight (Lbs.)	4.76
Pallet Qty	810.00
UPC Number	092326101288
I2of5	30092326101289



## Applicant

NAME OF LEGAL ENTITY	NAME OF BUSINESS(DBA)	BUSINESS
AMES CENTER FOR HEALTH AND HARMONY, L.C.	Creative Endeavors	(515) 291-5087

ADDRESS OF PREMISES	CITY	COUNTY	ZIP
518 Broad Street	Story City	Story	50248

MAILING ADDRESS	CITY	STATE	ZIP
518 Broad Street	Story City	Iowa	50248

## Contact Person

NAME	PHONE	EMAIL
Christina Morton	(515) 291-5087	ccscreativeendeavors@gmail.com

## License Information

LICENSE NUMBER	LICENSE/PERMIT TYPE	TERM	STATUS
WBN001320	Class B Native Wine Permit	12 Month	Submitted to Local Authority

TENTATIVE EFFECTIVE DATE	TENTATIVE EXPIRATION DATE	LAST DAY OF BUSINESS
Sep 1, 2021	Aug 31, 2022	

### SUB-PERMITS

Class B Native Wine Permit



# CLAIMS REGISTER REPORT

By Segment (Select Below)

Payable Dates 12/4/2021 - 12/17/2021

Vendor Name	Description (Payable)	Amount
<b>Department: 1110 - POLICE DEPARTMENT</b>		
COMPLETE COMMUNICATION	PHONE/INTERNET	85.26
KEY COOPERATIVE	FUEL	583.38
MGMC	MEMBERSHIP DEC	37.80
VERIZON WIRELESS	SERVICE	121.44
AXON ENTERPRISES, INC.	DATAPORT, BATTERY	2,982.44
MIDWEST RADAR & EQUIP.	RADAR CERTIFICATION	160.00
GALLS INC	POLICE SUPPLIES	196.59
GALLS INC	SABRE RED CROSSFIRE	42.00
INTERNATIONAL ASSOC OF CH	SURVIVAL ARMOR AND CARRI	190.00
IOWA POLICE CHIEFS ASSOC.	MEMBERSHIP CHIEF	125.00
ZERO 9 HOLSTERS	EQUIPMNET	657.25
911 CUSTOM	AMOR AND CARRIERS	6,003.00
FREEDOM FIRE	EXTINGUISHER INSPECT	36.53
GOOKIN FORD SALES INC	2020 AND 2008 MAINT.	51.05
SAM'S CLUB	LAPTOP BAGS	39.98
JAKE EDWARDS	REIMBURSE EQUIP.	179.75
IOWA DEPT OF PUBLIC SAFET	TERMINAL BILLING	300.00
		<b>Department 1110 - POLICE DEPARTMENT Total:</b>
		<b>11,791.47</b>
<b>Department: 1150 - FIRE DEPARTMENT</b>		
BLACK HILLS ENERGY	GAS SERVICE	235.64
COMPLETE COMMUNICATION	PHONE/INTERNET	185.43
TOYNE INC	PARTS SUPPLIES	628.16
FELD FIRE EQUIPMENT CO	HOSES/SPLIT	2,100.00
FREEDOM FIRE	EXTINGUISHER INSPECT	357.58
MPEC/NAPA Auto Parts	MISC SUPPLIES	126.72
		<b>Department 1150 - FIRE DEPARTMENT Total:</b>
		<b>3,633.53</b>
<b>Department: 1160 - FIRST RESPONDERS</b>		
KEY COOPERATIVE	FUEL	61.00
		<b>Department 1160 - FIRST RESPONDERS Total:</b>
		<b>61.00</b>
<b>Department: 1190 - ANIMAL CONTROL</b>		
HEARTLAND PET HOSPITAL	IMPOUND FEES	607.56
HEARTLAND PET HOSPITAL	IMPOUND FEES	155.34
		<b>Department 1190 - ANIMAL CONTROL Total:</b>
		<b>762.90</b>
<b>Department: 2210 - STREET/ROADWAY MAINT</b>		
AWS SERVICE CENTER	GARBAGE SERVICE	40.00
BLACK HILLS ENERGY	GAS SERVICE	70.94
COMPLETE COMMUNICATION	PHONE/INTERNET	107.58
KEY COOPERATIVE	FUEL	1,057.30
VERIZON WIRELESS	SERVICE	125.19
TRICKLES TIRE & AUTOMOTIV	NEW TIRES F550	1,124.00
HALLETT MATERIALS	ICE CONTROL SAND	201.99
HALLETT MATERIALS	ICE CONTROL SAND	237.95
PREFERRED PEST MANAGEME	PEST CONTROL	45.00
MC FARLAND CLINIC P.C.	LAB	82.00
MARTIN MARIETTA	STREET SUPPLIES	112.10
AUTOMATIC SYSTEMS CO	COMPUTER REPAIRS	483.00
MENARDS	SUPPLIES	69.90
MENARDS	HALLOWEEN	67.88
FREEDOM FIRE	EXTINGUISHER INSPECT	276.13
PDG	VINYL LABELING	30.00
PDG	VINYL LABELING	56.00
MPEC/NAPA Auto Parts	MISC SUPPLIES	59.97

**CLAIMS REGISTER REPORT**

Payable Dates: 12/4/2021 - 12/17/2021

Vendor Name	Description (Payable)	Amount
PREFERRED PEST MANAGEME	SERVICE	45.00
UNITY POINT CLINIC	TESTING/BK/TP	84.00
<b>Department 2210 - STREET/ROADWAY MAINT Total:</b>		<b>4,375.93</b>
<b>Department: 2250 - SNOW &amp; ICE</b>		
MENARDS	DRIVEWAY MARKER	34.10
IA DEPT TRANSPORTATION	SNOW FENCE/GLOVES/TUBIN	437.02
IA DEPT TRANSPORTATION	SNOW FENCE POSTS	171.30
<b>Department 2250 - SNOW &amp; ICE Total:</b>		<b>642.42</b>
<b>Department: 4410 - LIBRARY</b>		
AWS SERVICE CENTER	GARBAGE SERVICE	30.00
FREEDOM FIRE	EXTINGUISHER INSPECT	101.93
<b>Department 4410 - LIBRARY Total:</b>		<b>131.93</b>
<b>Department: 4430 - PARKS</b>		
AWS SERVICE CENTER	GARBAGE SERVICE	179.30
COMPLETE COMMUNICATION	PHONE/INTERNET	195.43
KEY COOPERATIVE	FUEL	344.26
MGMC	MEMBERSHIP DEC	37.80
VERIZON WIRELESS	SERVICE	101.66
MENARDS	SUPPLIES	98.82
MENARDS	MARKING PAINT, DICKIES	58.83
MENARDS	SHOP SUPPLIES/FERTILIZER SP	221.99
FREEDOM FIRE	EXTINGUISHER INSPECT	117.33
SAM'S CLUB	LAPTOP BAGS	39.98
MPEC/NAPA Auto Parts	MISC SUPPLIES	89.94
PREFERRED PEST MANAGEME	SERVICE	100.00
<b>Department 4430 - PARKS Total:</b>		<b>1,585.34</b>
<b>Department: 4440 - RECREATION DEPARTMENT</b>		
COMPLETE COMMUNICATION	PHONE/INTERNET	139.53
VERIZON WIRELESS	SERVICE	50.83
TREASURER STATE OF IOWA	REC/POOL TAXES	40.24
BSN SPORTS INC	PICKLEBALL/BB	114.48
VISA/SC PURCHASING	MISC.	62.99
<b>Department 4440 - RECREATION DEPARTMENT Total:</b>		<b>408.07</b>
<b>Department: 4445 - SWIMMING POOL</b>		
BLACK HILLS ENERGY	GAS SERVICE	35.00
COMPLETE COMMUNICATION	PHONE/INTERNET	144.53
SAM'S CLUB	LAPTOP BAGS	39.98
STORY CITY MUN ELEC UTILIT	SERVICE	99.52
<b>Department 4445 - SWIMMING POOL Total:</b>		<b>319.03</b>
<b>Department: 4450 - CEMETERY</b>		
AWS SERVICE CENTER	GARBAGE SERVICE	70.00
<b>Department 4450 - CEMETERY Total:</b>		<b>70.00</b>
<b>Department: 4470 - SPECIAL EVENTS</b>		
STORY CITY HISTORICAL SOCIE	FIRST HALF ALLOCATION	5,250.00
<b>Department 4470 - SPECIAL EVENTS Total:</b>		<b>5,250.00</b>
<b>Department: 5520 - ECONOMIC DEVELOPMENT</b>		
LIBBY PETERSEN	PROFESSIONAL SERVICE	333.34
<b>Department 5520 - ECONOMIC DEVELOPMENT Total:</b>		<b>333.34</b>
<b>Department: 5585 - TAX INCREMENT FINANCING</b>		
WINFIELD SOLUTIONS	DEVELOPMENT AGREEMENT	46,809.50
<b>Department 5585 - TAX INCREMENT FINANCING Total:</b>		<b>46,809.50</b>
<b>Department: 6611 - EXECUTIVE (MAYOR, ADM)</b>		
MGMC	MEMBERSHIP DEC	37.80
<b>Department 6611 - EXECUTIVE (MAYOR, ADM) Total:</b>		<b>37.80</b>
<b>Department: 6620 - FINANCIAL AD (CLERK,TREA)</b>		
COMPLETE COMMUNICATION	PHONE/INTERNET	172.51
MGMC	MEMBERSHIP DEC	37.80

**CLAIMS REGISTER REPORT**

**Payable Dates: 12/4/2021 - 12/17/2021**

<b>Vendor Name</b>	<b>Description (Payable)</b>	<b>Amount</b>
VERIZON WIRELESS	SERVICE	37.18
GATE HOUSE DB IOWA HOLDI	MINUTES/NOTICES	837.39
SAM'S CLUB	LAPTOP BAGS	39.98
STORY COUNTY AUDITOR	ELECTIONS 2021	754.37
VISA/SC PURCHASING	MISC.	29.50
VISA/SC PURCHASING	MISC.	30.00
<b>Department 6620 - FINANCIAL AD (CLERK,TREA) Total:</b>		<b>1,938.73</b>
<b>Department: 6640 - LEGAL SERVICES</b>		
LAW OFFICE OF KIRKE C. QUI	LEGAL FEES	1,200.00
LARSON LAW OFFICE	LEGAL SERVICES/ DEC	600.00
<b>Department 6640 - LEGAL SERVICES Total:</b>		<b>1,800.00</b>
<b>Department: 6650 - CITY HALL/SENIOR CENTER</b>		
AWS SERVICE CENTER	GARBAGE SERVICE	111.20
BLACK HILLS ENERGY	GAS SERVICE	256.47
FARNSWORTH GROUP	PROJECT ARCHITECT AND DES	16,692.63
FREEDOM FIRE	EXTINGUISHER INSPECT	128.33
AMERICAN BUSINESS PHONES	CORRECT TIME ON PHONES	25.00
DDM ELECTRIC	LABOR AND PARTS/BASEBOA	3,511.93
DDM ELECTRIC	NEW AND REPAIR EXIT LIGHT	1,070.65
PREFERRED PEST MANAGEME	SERVICE	75.00
<b>Department 6650 - CITY HALL/SENIOR CENTER Total:</b>		<b>21,871.21</b>
<b>Department: 7723 - DEBT SERVICE/FIRE</b>		
RELIANCE STATE BANK	FIRE TRUCK INTEREST	1,980.62
<b>Department 7723 - DEBT SERVICE/FIRE Total:</b>		<b>1,980.62</b>
<b>Department: 7793 - 2021 STREET SWEEPER</b>		
RELIANCE STATE BANK	STREET SWEEPER/INTEREST	864.64
<b>Department 7793 - 2021 STREET SWEEPER Total:</b>		<b>864.64</b>
<b>Department: 8763 - STREET IMPROVEMENT</b>		
FAIRVIEW DEVELOPMENT, LLC	DEVELOPMENT AGREEMENT	263,442.35
<b>Department 8763 - STREET IMPROVEMENT Total:</b>		<b>263,442.35</b>
<b>Department: 8775 - SO &amp; NO PARK PROJECT</b>		
MSA PROFESSIONAL SERVICES	NORTH PARK	1,330.00
<b>Department 8775 - SO &amp; NO PARK PROJECT Total:</b>		<b>1,330.00</b>
<b>Department: 9211 - STORM DRAINAGE</b>		
TREASURER STATE OF IOWA	LOST/WW/STORM	74.00
<b>Department 9211 - STORM DRAINAGE Total:</b>		<b>74.00</b>
<b>Department: 9810 - WATER UTILITY</b>		
AWS SERVICE CENTER	GARBAGE SERVICE	48.00
BLACK HILLS ENERGY	GAS SERVICE	86.93
COMPLETE COMMUNICATION	PHONE/INTERNET	179.20
KEY COOPERATIVE	FUEL	83.10
MGMC	MEMBERSHIP DEC	37.80
VERIZON WIRELESS	SERVICE	101.66
TREASURER STATE OF IOWA	WET	3,313.00
MUNICIPAL MANAGEMENT	SURVEY SYSTEM/ISOLATION O	1,500.00
ULINE	SUPPLIES	424.01
JETCO INC	PROGRAM UPLOAD AND INST	1,092.40
PITTSBURG TANK & TOWER M	CLEAN WATER TOWER EXTERI	15,096.00
KEYSTONE LABORATORIES	LAB TESTING	50.00
WIGEN COMPANIES	LABOR/TRAVEL	5,035.03
WATER ENVIRONMENT FED	MEMBERSHIP R.M.	160.00
FERGUSON WATERWORKS #2	WATER METERS	1,708.47
FERGUSON WATERWORKS #2	WATER METER	462.42
JOHN DEERE FINANCIAL	RANDY CLOTHING	59.98
HALL BACKHOE & TRENCHING	WATER MAIN 305 ELM	1,590.00
FREEDOM FIRE	EXTINGUISHER INSPECT	61.69
GOOKIN FORD SALES INC	2020 AND 2008 MAINT.	950.66
HAWKINS INC	WW CHEMICALS	2,150.36

**CLAIMS REGISTER REPORT**

**Payable Dates: 12/4/2021 - 12/17/2021**

<b>Vendor Name</b>	<b>Description (Payable)</b>	<b>Amount</b>
HAWKINS INC	WATER CHEMICALS	7,452.88
MPEC/NAPA Auto Parts	MISC SUPPLIES	41.48
STORY CITY MUN ELEC UTILIT	SERVICE	7,656.50
		<b>Department 9810 - WATER UTILITY Total:</b>
		<b>49,341.57</b>
<b>Department: 9815 - SEWER UTILITY</b>		
AWS SERVICE CENTER	GARBAGE SERVICE	48.00
BLACK HILLS ENERGY	GAS SERVICE	53.92
COMPLETE COMMUNICATION	PHONE/INTERNET	179.20
KEY COOPERATIVE	FUEL	231.67
MGMC	MEMBERSHIP DEC	37.80
VERIZON WIRELESS	SERVICE	101.66
TREASURER STATE OF IOWA	LOST/WW/STORM	633.00
AGSOURCE LABORATORIES	TESTING/ WW	165.50
AGSOURCE LABORATORIES	TESTING/ WW	165.50
AGSOURCE LABORATORIES	TESTING/ WW	148.00
KEYSTONE LABORATORIES	LAB TESTING	451.90
AUTOMATIC SYSTEMS CO	COMPUTER REPAIRS	295.50
BOONE COUNTY LANDFILL	GRIT	448.76
BLUE RIBBON PELHAM WATE	DISTILLED WATER	16.00
FREEDOM FIRE	EXTINGUISHER INSPECT	130.53
STORY CITY MUN ELEC UTILIT	SERVICE	4,415.74
VISA/SC PURCHASING	MISC.	30.00
MSA PROFESSIONAL SERVICES	SUMP PUMP YEAR 2	5,209.79
		<b>Department 9815 - SEWER UTILITY Total:</b>
		<b>12,762.47</b>
		<b>Grand Total:</b>
		<b>431,617.85</b>

## Report Summary

## Fund Summary

Fund	Payment Amount
001 - GENERAL FUND	50,354.48
110 - ROAD USE TAX	4,658.22
125 - TAX INCREMENT FINANCING	46,809.50
200 - DEBT SERVICE	2,845.26
313 - STREET IMPROVEMENT	263,442.35
324 - SO AND NO PARKS PROJECT	1,330.00
600 - WATER UTILITY	49,341.57
610 - SEWER UTILITY	12,762.47
740 - STORM WATER DRAINAGE	74.00
<b>Grand Total:</b>	<b>431,617.85</b>

## Account Summary

Account Number	Account Name	Payment Amount
001-1110-6210	DUES & SUBSCRIPTIONS	352.80
001-1110-6331	MOTOR VEHICLE OPER.	583.38
001-1110-6332	VEHICLE REPAIR & MAIN	51.05
001-1110-6350	EQUIPMENT REPAIR &	160.00
001-1110-6373	TELEPHONE	206.70
001-1110-6413	PAYMENTS TO OTHER A	300.00
001-1110-6504	MINOR EQUIPMENT	9,822.44
001-1110-6506	OFFICE SUPPLIES	39.98
001-1110-6507	MISC. OPERATING SUPP	275.12
001-1150-6371	UTILITIES	235.64
001-1150-6373	TELEPHONE	185.43
001-1150-6499	MISCELLANEOUS	126.72
001-1150-6504	MINOR EQUIPMENT	628.16
001-1150-6507	MISC. OPERATING SUPP	2,457.58
001-1160-6331	MOTOR VEHICLE OPER.	61.00
001-1190-6413	PAYMENTS TO OTHER A	762.90
001-2210-6320	BUILDING & GROUNDS	276.13
001-2210-6490	PROFESSIONAL SERVICE	84.00
001-4410-6320	BUILDING & GROUNDS	101.93
001-4410-6371	UTILITIES	30.00
001-4430-6210	DUES & SUBSCRIPTIONS	37.80
001-4430-6320	BUILDING & GROUNDS	274.98
001-4430-6331	MOTOR VEHICLE OPER.	434.20
001-4430-6373	TELEPHONE	297.09
001-4430-6498	CONTRACTUAL SERVICES	100.00
001-4430-6499	MISCELLANEOUS	179.30
001-4430-6507	MISC. OPERATING SUPP	261.97
001-4440-6332	VEHICLE REPAIR & MAIN	62.99
001-4440-6373	TELEPHONE	190.36
001-4440-6418	SALES TAX	40.24
001-4440-6727	CAPITAL EQUIPMENT	114.48
001-4445-6371	UTILITIES	134.52
001-4445-6373	TELEPHONE	144.53
001-4445-6507	MISC. OPERATING SUPP	39.98
001-4450-6320	BUILDING & GROUNDS	70.00
001-4470-6499	MISCELLANEOUS	5,250.00
001-5520-6499	MISCELLANEOUS	333.34
001-6611-6499	MISCELLANEOUS	37.80
001-6620-6373	TELEPHONE	209.69
001-6620-6402	PUBLICATION ADV/LEGA	837.39
001-6620-6490	PROFESSIONAL SERVICE	754.37
001-6620-6499	MISCELLANEOUS	37.80
001-6620-6506	OFFICE SUPPLIES	69.48
001-6620-6507	MISC. OPERATING SUPP	30.00

## Account Summary

Account Number	Account Name	Payment Amount
001-6640-6490	PROFESSIONAL SERVICE	1,800.00
001-6650-6320	BUILDING & GROUNDS	1,273.98
001-6650-6350	EQUIPMENT REPAIR &	25.00
001-6650-6371	UTILITIES	256.47
001-6650-6490	PROFESSIONAL SERVICE	16,692.63
001-6650-6499	MISCELLANEOUS	111.20
001-6650-6727	CAPITAL EQUIPMENT	3,511.93
110-2210-6181	CLOTHING ALLOWANCE	86.00
110-2210-6320	BUILDING & GROUNDS	129.87
110-2210-6331	MOTOR VEHICLE OPER.	1,057.30
110-2210-6332	VEHICLE REPAIR & MAIN	1,124.00
110-2210-6371	UTILITIES	70.94
110-2210-6373	TELEPHONE	232.77
110-2210-6490	PROFESSIONAL SERVICE	655.00
110-2210-6499	MISCELLANEOUS	107.88
110-2210-6526	ROAD MAINT. SUPPLIES	552.04
110-2250-6526	ROAD MAINT. SUPPLIES	642.42
125-5585-6499	MISCELLANEOUS	46,809.50
200-7723-6851	BOND INTEREST	1,980.62
200-7793-6851	BOND INTEREST	864.64
313-8763-6499	MISCELLANEOUS	263,442.35
324-8775-6490	PROFESSIONAL SERVICE	1,330.00
600-9810-6181	CLOTHING ALLOWANCE	59.98
600-9810-6210	DUES & SUBSCRIPTIONS	197.80
600-9810-6331	MOTOR VEHICLE OPER.	83.10
600-9810-6332	VEHICLE REPAIR & MAIN	950.66
600-9810-6371	UTILITIES	7,743.43
600-9810-6373	TELEPHONE	280.86
600-9810-6418	SALES TAX	3,313.00
600-9810-6490	PROFESSIONAL SERVICE	24,363.43
600-9810-6499	MISCELLANEOUS	109.69
600-9810-6507	MISC. OPERATING SUPP	10,068.73
600-9810-6520	METERS, CLAMPS, HYDR	2,170.89
610-9815-6210	DUES & SUBSCRIPTIONS	37.80
610-9815-6230	TRAVEL & TRAINING	30.00
610-9815-6331	MOTOR VEHICLE OPER.	231.67
610-9815-6371	UTILITIES	4,469.66
610-9815-6373	TELEPHONE	280.86
610-9815-6418	SALES TAX	633.00
610-9815-6490	PROFESSIONAL SERVICE	6,884.95
610-9815-6499	MISCELLANEOUS	178.53
610-9815-6507	MISC. OPERATING SUPP	16.00
740-9211-6800	CAPITAL FEE	74.00
	<b>Grand Total:</b>	<b>431,617.85</b>

## Project Account Summary

Project Account Key	Payment Amount
**None**	431,617.85
	<b>Grand Total:</b>
	<b>431,617.85</b>



**Detail Report**

**Date Range: 07/01/2020- 11/30/2021**

**Fund Summary**

	<b>Fund</b>	<b>Beginning Balance</b>	<b>Total Activity</b>	<b>Ending Balance</b>
001095044300	001 - GENERAL FUND	856830.26	137361.7	994191.96
022553044300	022 - HOUSING ASSISTANCE FUN	43880.95	627.95	44508.9
031441044300	031 - LIBRARY GIFT TRUST FUND	335760.1	8373.54	344133.64
032851044300	032 - TREES FOREVER PROGRAM	3778.24	-47.78	3730.46
033441044300	033 - GILBERT PUBLIC LIBRARY	18697.69	3372.83	22070.52
040552044300	040 - ECON DEV REVOLVING LOA	-42484.98	0	-42484.98
053981544300	053 - WW/MAINT OPER	10704.39	23.22	10727.61
061721944300	061 - SPECIAL ASSISTANCE FUND	77198.48	4733.13	81931.61
001095044300	110 - ROAD USE TAX	504741.9	84267.87	589009.77
115930044300	115 - PARTIAL SELF FUNDING	3422.94	-751.39	2671.55
125095044300	125 - TAX INCREMENT FINANCI	101532.88	407286.71	508819.59
126095044300	126 - TIF RESERVED FUND	154.39	0.33	154.72
134884644300	134 - FRAN KINNE ESTATE	1293000	-19360.46	1273639.54
135552044300	135 - I-35 DEVELOPMENT	26514.3	222028.7	248543
146876144300	146 - AMERICAN RESCUE PLAN	0	248415.75	248415.75
200771044300	200 - DEBT SERVICE	5691.85	135301.57	140993.42
311877244300	311 - DOWNTOWN IMPROVEME	1459.2	3.17	1462.37
312775044300	312 - CAPITAL PROJECTS	12709.69	17848.26	30557.95
313876344300	313 - STREET IMPROVEMENT	155631.59	114719.05	270350.64
314876444300	314 - CLUBHOUSE/TRAIL PROJEC	2567.47	5.57	2573.04
316876644300	316 - WATER PROJECTS	0	-11745.28	-11745.28
320877444300	320 - TIF STREETS	50343.26	-57345.8	-7002.54
323877344300	323 - SWIMMING POOL PROJECT	129579.56	281.07	129860.63
324877544300	324 - SO AND NO PARKS PROJEC	522419.78	-216572.38	305847.4
326877844300	326 - BONDS	2026979.74	4396.87	2031376.61
327877944300	327 - WASTEWATER TREATMENT	-89765.72	-126502.27	-216267.99
328878044300	328 - WWTP REMEDIATION	2414.31	5.25	2419.56
329875044300	329 - RR CROSSINGS PROJECT	-8683.4	-91	-8774.4
330875044300	330 - BROAD ST RECONSTRUCTIC	-26078.7	-566838.07	-592916.77
350095044300	350 - EQUIPMENT REPLACEMEN	106473.41	229595.41	336068.82
440842044300	440 - RECREATION CENTER	58484.24	126.86	58611.1
001095044300	500 - CEMETERY PERPETUAL CAF	49263.13	1580.58	50843.71
600981044300	600 - WATER UTILITY	187374.06	-9440.09	177933.97
601981044300	601 - WATER SINKING	26834.29	35120.88	61955.17
602981044300	602 - WATER IMPROVEMENT	170885.55	8043.44	178928.99
603981044300	603 - WATER RESERVE FUND	787.86	1.71	789.57
610981544300	610 - SEWER UTILITY	231467.2	86981.56	318448.76
611981544300	611 - SEWER SINKING	47331.73	7084.04	54415.77
612981544300	612 - SEWER IMP/REPL FUND	23765.68	13664.42	37430.1
613981544300	613 - SEWER RESERVE FUND	115680.46	250.98	115931.44
680584544300	680 - HOSPITAL ACCOUNT	8572.5	150144.51	158717.01
740921144300	740 - STORM WATER DRAINAGE	3762.66	18070.22	21832.88
751987044300	751 - GOLF COURSE TRUST FUNC	29289.04	2456.12	31745.16
800111144300	800 - POLICE FOREFEITURES	559.26	1.22	560.48
	<b>Grand Total:</b>	<b>\$7,079,531.24</b>	<b>\$933,479.97</b>	<b>\$8,013,011.21</b>
			<b>Fund Summary balance</b>	<b>\$8,013,011.21</b>
			<b>Petty cash</b>	<b>-\$150.00</b>
			<b>subtotal</b>	<b>\$8,012,861.21</b>

Plus Bank Statement Register Outstanding Credits	\$148,173.03
Total should match bank statement register	\$8,161,034.24
less outstanding Debits:	\$0.00
less any adjustments	
<b>Final total should match bank statement register</b>	<b>\$8,161,034.24</b>

Savings CDs

City of Story City, IA

# Account Summary

Date Range: 07/01/2021 - 11/30/2021

Account	Name	Beginning Balance	Total Activity	Ending Balance
<b>AccountCode: 1101 - GENERAL SAVINGS ACCOUNT</b>				
<u>001-1101</u>	GENERAL FUND SAV ACCT	576,176.93	1,208.62	577,385.55
<u>022-1101</u>	GENERAL SAVINGS ACCOUNT	0.00	0.00	0.00
<u>031-1101</u>	LIB GIFT TRUST SAV ACCT	107,170.03	105,233.90	212,403.93
<u>032-1101</u>	GENERAL SAVINGS ACCOUNT	0.00	0.00	0.00
<u>040-1101</u>	ECON DEV REV SAV ACCT	210,223.19	352.72	210,575.91
<u>053-1101</u>	GENERAL SAVINGS ACCOUNT	0.00	0.00	0.00
<u>061-1101</u>	GENERAL SAVINGS ACCOUNT	0.00	0.00	0.00
<u>110-1101</u>	GENERAL SAVINGS ACCOUNT	0.00	0.00	0.00
<u>125-1101</u>	GENERAL SAVINGS ACCOUNT	0.00	0.00	0.00
<u>135-1101</u>	GENERAL SAVINGS ACCOUNT	0.00	0.00	0.00
<u>146-1101</u>	GENERAL SAVINGS ACCOUNT	0.00	0.00	0.00
<u>200-1101</u>	DEBT SERVICE SAV ACCT	141,101.44	236.75	141,338.19
<u>350-1101</u>	EQUIP REPL SAV ACCT	15,083.74	25.31	15,109.05
<u>440-1101</u>	GENERAL SAVINGS ACCOUNT	0.00	0.00	0.00
<u>500-1101</u>	CEM PERP CARE SAV ACCT	607.92	1.01	608.93
<u>600-1101</u>	WATER SAV ACCT	104,262.95	218.70	104,481.65
<u>601-1101</u>	WATER SINKING SAVINGS ACCT	79,470.98	166.70	79,637.68
<u>602-1101</u>	WATER IMPROVE SAV ACCT	5,635.85	11.82	5,647.67
<u>610-1101</u>	SEWER SAV ACCT	189,430.79	397.36	189,828.15
<u>612-1101</u>	WW/MO REPL SAV ACCT	164,184.78	258.13	164,442.91
<u>613-1101</u>	SEWER RESERVE FUND SAV ACCT	0.00	0.00	0.00
<u>680-1101</u>	HOSPITAL SAV ACCT	281,304.95	471.98	281,776.93
		<b>1,874,653.55</b>	<b>108,583.00</b>	<b>1,983,236.55</b>
<b>Total AccountCode: 1101 - GENERAL SAVINGS ACCOUNT:</b>				
<b>AccountCode: 1121 - PETTY CASH</b>				
<u>001-1121</u>	PETTY CASH	150.00	0.00	150.00
		<b>150.00</b>	<b>0.00</b>	<b>150.00</b>
<b>Total AccountCode: 1121 - PETTY CASH:</b>				
<b>AccountCode: 1141 - GENERAL CD</b>				
<u>001-1141</u>	GENERAL CD	0.00	0.00	0.00
		<b>0.00</b>	<b>0.00</b>	<b>0.00</b>
<b>Total AccountCode: 1141 - GENERAL CD:</b>				
<b>AccountCode: 1142 - LIBRARY TRUST #5910</b>				
<u>031-1142</u>	LIBRARY TRUST #5910	0.00	0.00	0.00
		<b>0.00</b>	<b>0.00</b>	<b>0.00</b>
<b>Total AccountCode: 1142 - LIBRARY TRUST #5910:</b>				
<b>AccountCode: 1143 - LIBRARY TRUST #5911</b>				
<u>031-1143</u>	LIBRARY TRUST #5911	105,000.00	-105,000.00	0.00
		<b>105,000.00</b>	<b>-105,000.00</b>	<b>0.00</b>
<b>Total AccountCode: 1143 - LIBRARY TRUST #5911:</b>				

**Detail Report**

Date Range: 07/01/2021 - 11/30/2021

Account	Name	Beginning Balance	Total Activity	Ending Balance
AccountCode: 1147 - CEM PERP CARE CD	CEM PERP CARE CD	27,956.90	0.00	27,956.90
<a href="#">500-1147</a>		27,956.90	0.00	27,956.90
Total AccountCode: 1147 - CEM PERP CARE CD:				
AccountCode: 1149 - SEWER CD	SEWER CD	0.00	0.00	0.00
<a href="#">610-1149</a>		0.00	0.00	0.00
Total AccountCode: 1149 - SEWER CD:				
AccountCode: 1160 - HOSPITAL CD	HOSPITAL CD	0.00	0.00	0.00
<a href="#">680-1160</a>		0.00	0.00	0.00
Total AccountCode: 1160 - HOSPITAL CD:				
<b>Grand Totals:</b>		<b>2,007,760.45</b>	<b>3,583.00</b>	<b>2,011,343.45</b>

# Account Summary

Date Range: 07/01/2021 - 11/30/2021

Account	Name	Beginning Balance	Total Activity	Ending Balance
<b>AccountCode: 1000 - CASH (Claim on Pool)</b>				
001-1000	GENERAL CASH (Claim on Pool)	856,680.26	137,361.70	994,041.96
022-1000	HOUSING ASSIST CASH (Claim on Pool)	43,880.95	627.95	44,508.90
031-1000	LIB GIFT TRUST CASH (Claim on Pool)	335,760.10	8,373.54	344,133.64
032-1000	TREES FOREVER CASH (Claim on Pool)	3,778.24	-47.78	3,730.46
033-1000	GILBERT LIBRARY CASH (Claim on Pool)	18,697.69	3,372.83	22,070.52
053-1000	WW/MAINT OPER CASH (Claim on Pool)	10,704.39	23.22	10,727.61
061-1000	SPECIAL ASSIST CASH (Claim on Pool)	77,198.48	4,733.13	81,931.61
110-1000	ROAD USE TAX CASH (Claim on Pool)	504,741.90	84,267.87	589,009.77
115-1000	PARTIAL SELF FUND CASH (Claim on Pool)	3,422.94	-751.39	2,671.55
125-1000	TAX INCREMENT FINANCE CASH (Claim on Pool)	101,532.88	407,286.71	508,819.59
126-1000	TIF RESERVE FUND CASH (Claim on Pool)	154.39	0.33	154.72
134-1000	FRAN KINNE ESTATE CASH (CLAIM ON POOL)	0.00	-19,965.88	-19,965.88
135-1000	I-35 DEVELOPMENT CASH (Claim on Pool)	26,514.30	222,028.70	248,543.00
146-1000	AMERICAN RESCUE PLAN(Claim on Pool)	0.00	248,415.75	248,415.75
200-1000	DEBT SERV CASH (Claim on Pool)	5,691.85	135,301.57	140,993.42
311-1000	DOWNTOWN IMPROVE CASH (Claim on Pool)	1,459.20	3.17	1,462.37
312-1000	CAPITAL PROJECTS CASH (Claim on Pool)	12,709.69	17,848.26	30,557.95
313-1000	STREET IMPROVE CASH (Claim on Pool)	155,631.59	114,719.05	270,350.64
314-1000	CLUBHOUSE/TRAIL CASH (Claim on Pool)	2,567.47	5.57	2,573.04
316-1000	WATER PROJECTS (Claim on Pool)	0.00	-11,745.28	-11,745.28
320-1000	TIF STREETS (Claim on Pool)	50,343.26	-57,345.80	-7,002.54
323-1000	SWIMMING POOL PROJ CASH (Claim on Pool)	129,579.56	281.07	129,860.63
324-1000	SO & NO PARKS PROJ CASH (Claim on Pool)	522,419.78	-216,572.38	305,847.40
326-1000	BONDS CASH (Claim on Pool)	2,026,979.74	4,396.87	2,031,376.61
327-1000	WW TREAT PROJ CASH CLAIM	-89,765.72	-126,502.27	-216,267.99
328-1000	WWTP REMEDIATION CASH CLAIM	2,414.31	5.25	2,419.56
329-1000	RR CROSSINGS PROJECT (Claim on Pool)	-8,683.40	-91.00	-8,774.40
330-1000	BROAD ST RECONSTRUCTION	-26,078.70	-566,838.07	-592,916.77
334-1000	FRAN KINNE ESTATE CASH (Claim on Pool)	1,293,000.00	605.42	1,293,605.42
350-1000	EQUIP REPLACE FUND CASH (Claim on Pool)	106,473.41	229,595.41	336,068.82
440-1000	RECREATION CENTER CASH (Claim on Pool)	58,484.24	126.86	58,611.10
500-1000	CEM PERP CARE CASH (Claim on Pool)	49,263.13	1,580.58	50,843.71
500-1000	WATER SINK CASH (Claim on Pool)	187,374.06	-25,440.09	161,933.97
601-1000	WATER SINK CASH (Claim on Pool)	26,834.29	49,120.88	75,955.17
602-1000	WATER IMPROV CASH (Claim on Pool)	170,885.55	10,043.44	180,928.99
603-1000	WATER RESERVE CASH (Claim on Pool)	787.86	1.71	789.57

**Detail Report**

Date Range: 07/01/2021 - 11/30/2021

Account	Name	Beginning Balance	Total Activity	Ending Balance
610-1000	SEWER UTILITY CASH (Claim on Pool)	231,467.20	74,381.56	305,848.76
611-1000	SEWER SINK CASH(CLAIM ON POOL)	47,331.73	16,284.04	63,615.77
612-1000	SEWER/REPL FUND CASH (Claim on Pool)	23,765.68	17,064.42	40,830.10
613-1000	SEWER RESERVE FUND (Claim on Pool)	115,680.46	250.98	115,931.44
680-1000	HOSPITAL CASH (Claim on Pool)	8,572.50	150,144.51	158,717.01
740-1000	STORM WATER DRAIN CASH (Claim on Pool)	3,762.66	18,070.22	21,832.88
751-1000	GOLF COURSE TRUST CASH (Claim on Pool)	29,289.04	2,456.12	31,745.16
800-1000	POLICE FORFEIT CASH (Claim on Pool)	559.26	1.22	560.48
<b>Total AccountCode: 1000 - CASH (Claim on Pool):</b>		<b>7,121,866.22</b>	<b>933,479.97</b>	<b>8,055,346.19</b>

**AccountCode: 1101 - GENERAL SAVINGS ACCOUNT**

001-1101	GENERAL FUND SAV ACCT	576,176.93	1,208.62	577,385.55
031-1101	LIB GIFT TRUST SAV ACCT	107,170.03	105,233.90	212,403.93
040-1101	ECON DEV REV SAV ACCT	210,223.19	352.72	210,575.91
200-1101	DEBT SERVICE SAV ACCT	141,101.44	236.75	141,338.19
350-1101	EQUIP REPL SAV ACCT	15,083.74	25.31	15,109.05
500-1101	CEM PERP CARE SAV ACCT	607.92	1.01	608.93
600-1101	WATER SAV ACCT	104,262.95	218.70	104,481.65
601-1101	WATER SINKING SAVINGS ACCT	79,470.98	166.70	79,637.68
602-1101	WATER IMPROVE SAV ACCT	5,635.85	11.82	5,647.67
610-1101	SEWER SAV ACCT	189,430.79	397.36	189,828.15
612-1101	WW/MO REPL SAV ACCT	164,184.78	258.13	164,442.91
680-1101	HOSPITAL SAV ACCT	281,304.95	471.98	281,776.93
<b>Total AccountCode: 1101 - GENERAL SAVINGS ACCOUNT:</b>		<b>1,874,653.55</b>	<b>108,583.00</b>	<b>1,983,236.55</b>

**AccountCode: 1143 - LIBRARY TRUST #5911**

031-1143	LIBRARY TRUST #5911	105,000.00	-105,000.00	0.00
<b>Total AccountCode: 1143 - LIBRARY TRUST #5911:</b>		<b>105,000.00</b>	<b>-105,000.00</b>	<b>0.00</b>
<b>Grand Totals:</b>		<b>9,101,519.77</b>	<b>937,062.97</b>	<b>10,038,582.74</b>

# Fund Summary

Fund	Beginning Balance	Total Activity	Ending Balance
001 - GENERAL FUND	1,432,857.19	138,570.32	1,571,427.51
022 - HOUSING ASSISTANCE FUND	43,880.95	627.95	44,508.90
031 - LIBRARY GIFT TRUST FUND	547,930.13	8,607.44	556,537.57
032 - TREES FOREVER PROGRAM	3,778.24	-47.78	3,730.46
033 - GILBERT PUBLIC LIBRARY	18,697.69	3,372.83	22,070.52
040 - ECON DEV REVOLVING LOAN	210,223.19	352.72	210,575.91
053 - WW/MAINT OPER	10,704.39	23.22	10,727.61
061 - SPECIAL ASSISTANCE FUND	77,198.48	4,733.13	81,931.61
110 - ROAD USE TAX	504,741.90	84,267.87	589,009.77
115 - PARTIAL SELF FUNDING	3,422.94	-751.39	2,671.55
125 - TAX INCREMENT FINANCING	101,532.88	407,286.71	508,819.59
126 - TIF RESERVED FUND	154.39	0.33	154.72
134 - FRAN KINNE ESTATE	1,293,000.00	-19,360.46	1,273,639.54
135 - I-35 DEVELOPMENT	26,514.30	222,028.70	248,543.00
146 - AMERICAN RESCUE PLAN	0.00	248,415.75	248,415.75
200 - DEBT SERVICE	146,793.29	135,538.32	282,331.61
311 - DOWNTOWN IMPROVEMENT	1,459.20	3.17	1,462.37
312 - CAPITAL PROJECTS	12,709.69	17,848.26	30,557.95
313 - STREET IMPROVEMENT	155,631.59	114,719.05	270,350.64
314 - CLUBHOUSE/TRAIL PROJECT	2,567.47	5.57	2,573.04
316 - WATER PROJECTS	0.00	-11,745.28	-11,745.28
320 - TIF STREETS	50,343.26	-57,345.80	-7,002.54
323 - SWIMMING POOL PROJECT	129,579.56	281.07	129,860.63
324 - SO AND NO PARKS PROJECT	522,419.78	-216,572.38	305,847.40
326 - BONDS	2,026,979.74	4,396.87	2,031,376.61
327 - WASTEWATER TREATMENT PLANT	-89,765.72	-126,502.27	-216,267.99
328 - WWTP REMEDIATION	2,414.31	5.25	2,419.56
329 - RR CROSSINGS PROJECT	-8,683.40	-91.00	-8,774.40
330 - BROAD ST RECONSTRUCTION	-26,078.70	-566,838.07	-592,916.77
350 - EQUIPMENT REPLACEMENT FUND	121,557.15	229,620.72	351,177.87
440 - RECREATION CENTER	58,484.24	126.86	58,611.10
500 - CEMETERY PERPETUAL CARE	49,871.05	1,581.59	51,452.64
600 - WATER UTILITY	291,637.01	-25,221.39	266,415.62
601 - WATER SINKING	106,305.27	49,287.58	155,592.85
602 - WATER IMPROVEMENT	176,521.40	10,055.26	186,576.66
603 - WATER RESERVE FUND	787.86	1.71	789.57
610 - SEWER UTILITY	420,897.99	74,778.92	495,676.91
611 - SEWER SINKING	47,331.73	16,284.04	63,615.77
612 - SEWER IMP/REPL FUND	187,950.46	17,322.55	205,273.01
613 - SEWER RESERVE FUND	115,680.46	250.98	115,931.44
680 - HOSPITAL ACCOUNT	289,877.45	150,616.49	440,493.94
740 - STORM WATER DRAINAGE	3,762.66	18,070.22	21,832.88

# Fund Summary

751 - GOLF COURSE TRUST FUND	29,289.04	2,456.12	31,745.16
800 - POLICE FOREFEITURES	559.26	1.22	560.48
<b>Grand Total:</b>	<b>9,101,519.77</b>	<b>937,062.97</b>	<b>10,038,582.74</b>

# November

## Water

Completed all well draw downs

Completed Meters/rechecks

Completed Bac-T samples

Replaced valve at Washington/Lafayette

Boil order for the valve replacement completed

Worked with Dose on getting meters for the mall

Check sump pump at 733 State St

Water tower cleaned

Main repair at 703 Elm

Monthly walk through/ maintenance

Wigens cleaned both RO skids

Worked on chemical feed lines

Completed all locates

## Wastewater

Weekly & monthly sampling. (TSS, Ammonia, BOD, Tank Samples)

Monthly Maintenance: cleaning, greasing, exercising valves. Calibrated the influent flow meter.

Continued increased Aluminum testing to monitor for regulations coming down the line.

DDM Electric was out and replaced the starter for raw pump number 1.



Automatic Systems was out to take a look at SBR Bridge drive Number 2. It keeps tripping out the braker and causing alarms that have to be taken care of (calls out and caused OT) Replace the heaters on the starter if that doesn't work, we will have to look into it further.

Hauled Grit to the dump.

Took the UV System out of service for the year. It went well and will be stored inside during the winters.

Sewer main plug out by McDonalds. Plug caused by grease. McDonalds is the only contributor on that line, but has submitted FOG cleanout reports on a regular basis. (Far more often than we require)

Dwain and I cut down and burned 2 of the 4 reed beds for the year but will have to wait to do the other 2 until it freezes up as they were too soft to walk in.

Josh Green with Central Pump finished doing our pump maintenance for the year. Raw Pump number 3 will need repairs.

Had Engineering interviews.

Dwain is still working on testing.

### **Street Department's Activities for November**

1. Filled several potholes
2. Had final walkthrough on Broad St. project
3. Swept streets
4. Maintained brush sites/leaf season
5. Automatic systems came and worked on south storm gate valve. Will need new software done to keep working properly
6. Raked/vacuumed leaves at cemetery
7. Received rebuilt 6" trash pump from story county emergency management
8. Repaired window on '99 Chevy dump truck
9. Started installing snow fence
10. Graded rock areas by soccer fields
11. Put salt spreader on F550
12. Put wing and front plow on '09 International dump truck
13. Trickle's installed new steer tires on F550
14. Ben and Mike had 3T continuing ed course
15. Started putting up snow markers around town to mark obstacles and roadway
16. Winterized all sprayers and put away for winter
17. Started working on 2022-2023 budget
18. Hauled 2 loads of sand from Hallet's in Ames
19. Ty Paysen started working
20. Had 1 traditional burial and 1 infant burial

### **Scheduled Activities for December**

1. Haul compost and wood chips
2. Snow removal and ice control
3. Finish installing snow markers
4. Maintain and repair equipment
5. Finish installing snow fence

**STORY CITY PARKS AND RECREATION DEPARTMENT  
MONTHLY ACTIVITIES REPORT  
NOVEMBER 2021**

- Council meeting on 11/1 was at Fairview Lodge
- I attended Council meeting to give yearly update and preliminary budget proposals for Parks and Rec
- Cole and I cut up and hauled away a large branch in North Park that had fallen
- Cole and I cut down 2 Crabapple trees behind City Hall, then dug area down a couple inches with the skid loader and added rock to this area to make a small parking lot for employees. 11/2, 11/3
- Caliber worked on the "S" table in North Park on 11/5
- Basketball league games started 11/6
- Cab and snowblower were installed on our John Deere 1550 mower on 11/9, we took the snow blower off and put the mower deck back on to mulch leaves this fall
- Installation company installed the two rocker features next to the existing play structure in North Park on 11/9 and finished up all other playground installation
- Substantial completion walk-through with MSA and Caliber Concrete for North Park on 11/12. They have a few items left to finish up, mostly in the spring, but play equipment is all done and ready
- We took down fencing and caution tape at North Park and picked up construction debris, branches, etc. on 11/15. And will have playgrounds/swings open for use now.
- Blew leaves out of S-table and playground at North Park and mulched them up on 11/15
- Mulched leaves in parks on 11/16 and 11/17
- Cole and I attended our annual pesticide applicator's license continuing ed course online 11/18
- Went to Iowa Recycling Products in Iowa Falls on 11/19 and picked up 25- 4"x6"x12' black recycled plastic timbers to use as parking lot posts in North Park and South Park
- Moved picnic tables and trash cans back into small shelter that was moved at North Park
- Put snow markers out along trails and sidewalks where we remove snow at 11/23
- Started working on 2022/2023 budgets
- Mulched leaves in parks on 11/29
- Cleaned out Brown building and loaded up all the benches from Broad St and Penn to store in there for the winter. 11/30
- Cole and I pulled out all the old parking posts in South Park on 11/29 and 11/30.

# Story City Police Department

## Summary Report

11/01/2021 00:00:00 - 11/30/2021 23:59:59

### Quick Overview

**Calls for Service: 349**  
**Outreach Events: 1**  
**Number of Arrests: 3**

**Traffic Stops: 31**  
**Extra Patrol: 26**  
**Total Charges Filed: 3**

**New Cases: 29**  
**Fire Alarms: 1**  
**Juvenile Referrals: 0**

## Calls For Service

### Officer Involved

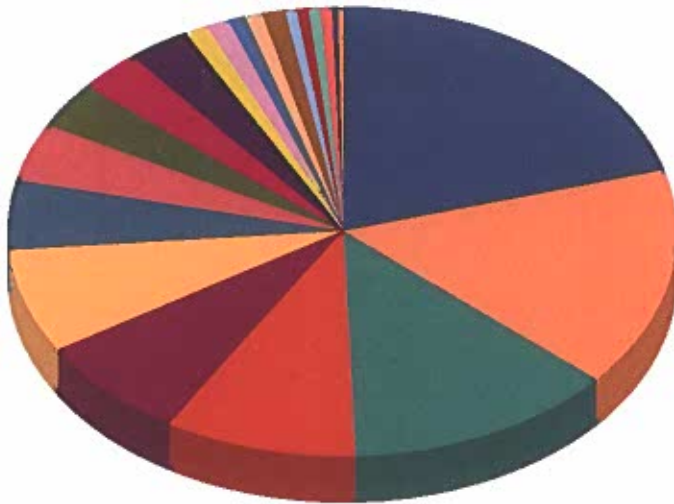

OUTREACH / COMMUNITY SERVICE	20.6%
BUSINESS SECURITY CHECK	15.9%
GENERAL COMPLAINTS	13.0%
TRAFFIC STOP / ENFORCEMENT	9.0%
EXTRA PATROL	7.5%
FOLLOW UP	7.5%
MEDICAL CALL	4.9%
THEFT/BURGLARY/PROPERTY CALLS	4.3%
LAW DEPARTMENT ASSIST	3.2%
SUSPICIOUS ACTIVITY	3.2%
COLLISION	2.9%
DOMESTIC DISPUTE	1.2%
WELFARE CHECK	1.2%
ADMINISTRATIVE ACTIVITY	0.9%
DRUGS AND ALCOHOL	0.9%
HARASSMENT	0.9%
ALARM	0.6%
CHEMICAL SPILL/ODOR	0.6%
CIVIL MATTER	0.6%
EQUIPMENT/SIGN MALFUNCTION	0.6%
VIOLATION OF NO CONTACT ORDER	0.3%
WARRANT SERVICE	0.3%
<b>Total:</b>	<b>100.0%</b>

## Events by Day

Officer Involved

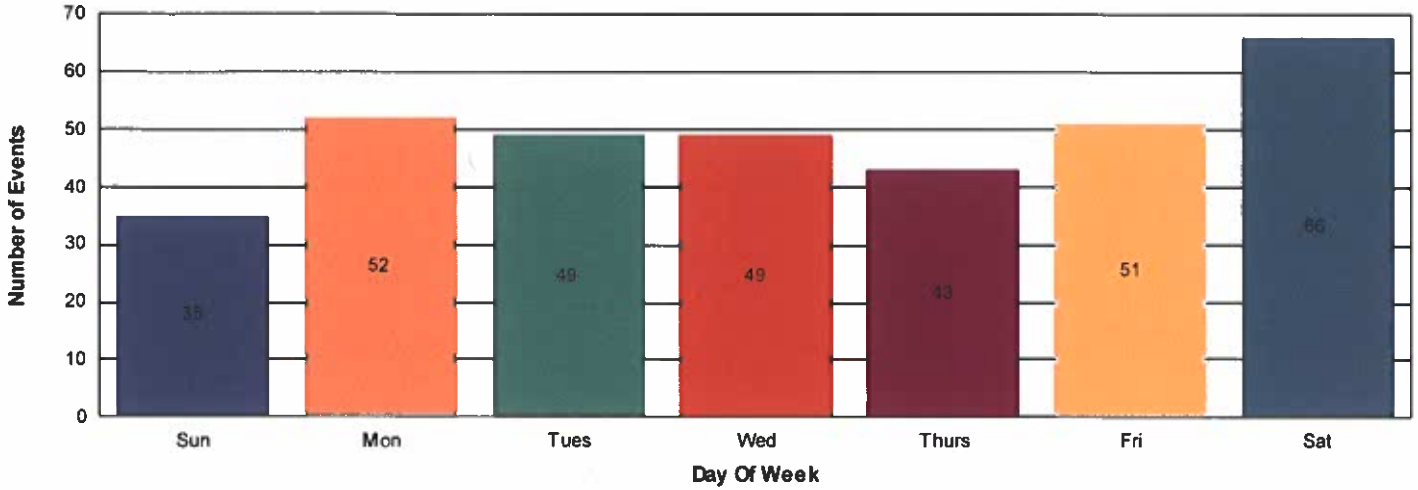

## Events by Hour - All Days

Officer Involved

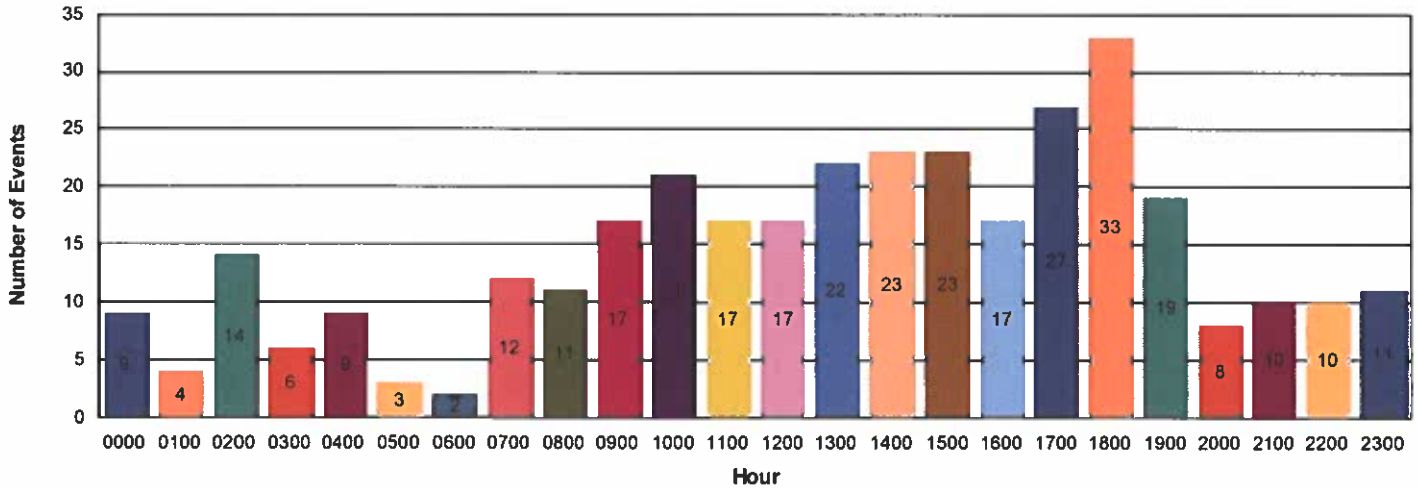

## Events by Hour

For Sunday

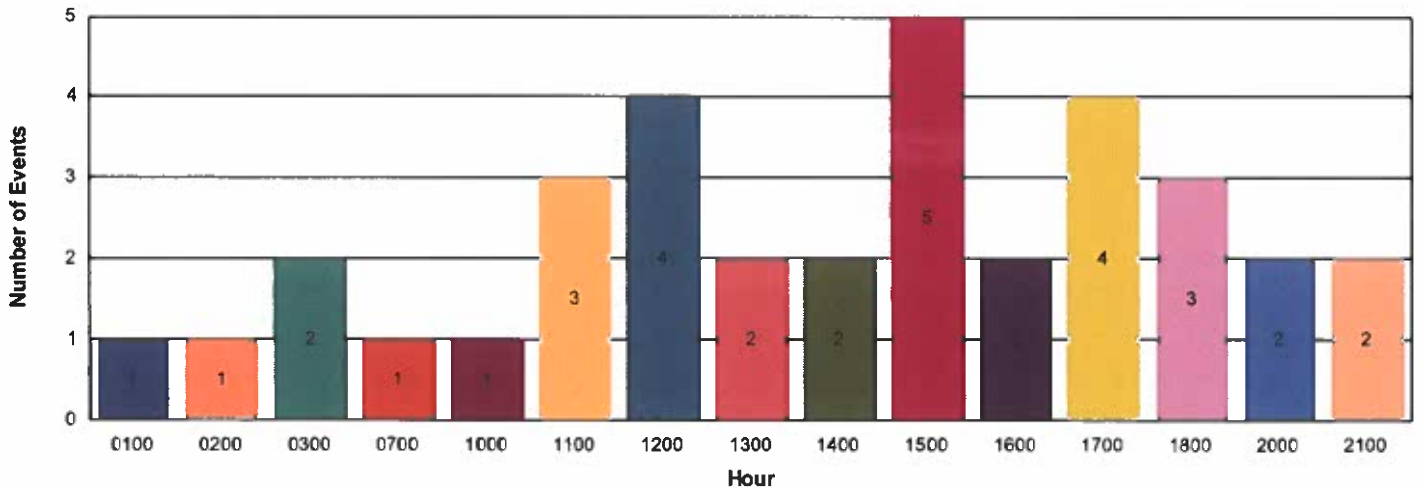

### CAD Event Breakdown by Day - All Events

	Sun	Mon	Tues	Wed	Thurs	Fri	Sat	Total
<b>TOTAL</b>	<b>35</b>	<b>52</b>	<b>49</b>	<b>51</b>	<b>45</b>	<b>51</b>	<b>66</b>	<b>349</b>
ANIMAL CALL	2	0	2	1	0	1	2	8
BUSINESS SECURITY CHECK	6	3	3	4	9	8	22	55
CHEMICAL SPILL/ODOR	0	1	1	0	0	0	0	2
CITIZEN CONTACT	1	2	6	8	1	1	1	20
CIVIL COURT PROCESS SERVICE	0	0	0	1	1	0	0	2
CIVIL MATTER	0	0	0	0	0	2	0	2
DOMESTIC DISPUTE	1	2	0	0	1	0	0	4
DRUG ACTIVITY/INVESTIGATION	0	1	0	0	0	0	2	3
EQUIPMENT/SIGN MALFUNCTION	0	0	0	1	0	1	0	2
EVIDENCE TRANSPORT/PICK UP	0	0	1	0	0	0	0	1
EXTRA PATROL	5	3	3	2	3	1	9	26
FINGER PRINTING	0	0	1	1	0	0	0	2
FIRE ALARM	0	1	0	0	0	0	0	1
FOLLOW UP	1	7	3	4	4	4	3	26
GENERAL ALARM BANK / RESIDENTI	1	0	0	0	0	0	0	1
GENERAL INFO/COMPLAINT/ASSIST	0	2	2	0	2	0	4	10
HARASSMENT	1	1	0	1	0	0	0	3
HIT & RUN PROPERTY DAMAGE	0	0	2	0	0	1	1	4
INDECENT EXPOSURE	0	0	0	0	0	1	0	1
JUVENILE TROUBLE	0	0	0	1	0	0	0	1
LAW DEPARTMENT ASSIST	1	1	1	4	3	0	1	11
LOST OR FOUND PROPERTY	1	0	1	0	1	0	0	3
MEDICAL ASSIST/AMBULANCE CALL	1	3	1	6	3	2	3	19
MOTOR VEH CRASH/PROP DAMAGE	0	2	0	0	0	2	1	5
MOTORIST ASSISTANCE	1	1	0	0	1	0	2	5
OPEN DOOR	0	0	0	1	1	0	0	2
OUTREACH	0	0	0	1	0	0	0	1
PARKING ENFORCEMENT/COMPLAINT	0	0	2	3	1	0	0	6
RECKLESS DRIVER	1	2	4	1	1	4	2	15
RESIDENCE CHECK	6	8	2	5	9	8	1	39
SCAM	0	0	0	0	0	0	1	1
SUSPICIOUS PERSON/VEH/ACTIVITY	0	1	3	1	1	0	3	9
THEFT / FRAUD / FORGERY	0	1	1	2	0	1	0	5
TRAFFIC HAZARD	1	0	0	0	0	1	1	3
TRAFFIC STOP / ENFORCEMENT	2	4	5	2	2	11	5	31
TRAINING	0	1	0	0	0	0	0	1
TRESPASS	0	1	0	0	0	0	0	1
VANDALISM / CRIMINAL MISCHIEF	0	2	1	1	1	0	1	6
VEHICLE IN DITCH	0	1	0	0	0	0	0	1
VEHICLE UNLOCK	0	1	3	0	0	1	0	5
VIOLATION OF NO CONTACT ORDER	0	0	0	0	0	1	0	1
WARRANT SERVICE	1	0	0	0	0	0	0	1
WELFARE CHECK	2	0	1	0	0	0	1	4

## Offense Numbers

A report can have more than one offense. The total for this table may be larger than the number of reports listed on page 1. This data is from the Mobile database and may not reflect final data in RMS as offenses may change during the approval process.

	Sun	Mon	Tues	Wed	Thurs	Fri	Sat	Total
<b>TOTAL</b>	<b>1</b>	<b>8</b>	<b>7</b>	<b>3</b>	<b>3</b>	<b>3</b>	<b>5</b>	<b>30</b>
ALL OTHER NON REPORTABLE	0	1	0	0	1	0	1	3
ALL OTHER OFFENSES	0	0	0	0	1	0	0	1
ANIMAL AT LARGE	1	0	0	0	0	0	0	1
ASSIST OTHER AGENCY	0	0	1	0	0	0	0	1
COLLISION REPORT	0	2	1	0	0	1	2	6
COUNTERFEITING/FORGERY	0	0	1	0	0	0	0	1
CRIMINAL MISCHIEF 2ND DEGREE	0	0	1	0	0	0	1	2
CRIMINAL MISCHIEF 4TH DEGREE	0	1	0	0	0	1	0	2
CRIMINAL MISCHIEF 5TH DEGREE	0	0	0	0	1	0	0	1
DEATH INVESTIGATION	0	0	1	0	0	0	0	1
DOMESTICE ASSAULT/2ND OFFENSE	0	0	1	0	0	0	0	1
DRIVING UNDER SUSPENSION	0	1	0	0	0	0	0	1
HARASSMENT BY COMMUNICATION - ALL OTHER OFFENSES	0	1	0	1	0	0	0	2
POSSESS TOBACCO UNDERAGE - VAPING	0	0	0	1	0	0	0	1
THEFT 5TH DEGREE - ALL OTHER LARCENY	0	2	1	1	0	1	0	5
THEFT BY DECEPTION - IMPERSONATION	0	0	0	0	0	0	1	1

### Charge Numbers

	Wed	Thurs	Sat	Total
<b>TOTAL</b>	<b>1</b>	<b>1</b>	<b>1</b>	<b>3</b>
CRIMINAL MISCHIEF 5TH DEGREE	0	1	0	1
DOMESTICE ASSAULT/2ND OFFENSE	0	0	1	1
DRIVING UNDER SUSPENSION	1	0	0	1



Regular Meeting

Of the

Story City Municipal Electric Utility Board of Trustees

December 15, 2021

**Tentative Agenda**

**Approval of Minutes of November 17<sup>th</sup>, 2021 Board Meeting**

**Presentation by Kim Peterson of Key Elements Consulting**

**Monthly Financial Reports**

**Summary of Work and Activities**

**Discuss Wage Study and Employee Raises**

**Closed Session-pursuant to Iowa Code Chapter 21.5 (1) (c)  
(If Needed)**

**Adjourn**

## **Summary of Work and Activities**

### **Production**

- Particulate testing results came back well below limits. Waiting to hear from DNR
- Have Shermco coming in to replace relay for north feeder and do breaker maintenance

### **Distribution**

- Maverick Project done
- Jacobson house on D-65 done
- Dose Steel (Old VF Mall) project
- Next phase of duplexes on Larson

### **Office**

- Postcard billing starting first of the year
- We have Facebook

**STORY CITY MUNICIPAL ELECTRIC UTILITY  
STATEMENT OF OPERATIONS  
FOR THE 11TH MONTH PERIOD ENDING NOVEMBER 2021**

	Current Month	Year to Date 2021	Year to Date 2020
<b>Operating Revenue:</b>			
Sales of Electricity -			
Residential	166158.90	1989847.99	1852861.45
Commercial	43121.51	490106.48	464712.79
Large Power	283305.53	2808637.40	2646935.33
Municipal	17716.51	185264.51	179707.17
<b>SUBTOTAL</b>	<b>510302.45</b>	<b>5473856.38</b>	<b>5144216.74</b>
Other Operating Revenue	1282.76	18174.95	20030.89
<b>TOTAL OPERATING REVENUE</b>	<b>511585.21</b>	<b>5492031.33</b>	<b>5164247.63</b>
<b>Operating Expenses:</b>			
Power Production -			
Purchased Power	313995.49	3408726.59	2959103.70
Labor	15308.27	107473.73	98509.69
Fuel - Diesel	8948.61	189399.53	38412.56
Fuel - Gas	0.00	3847.60	3526.15
Lubricating Oil	2836.94	19858.55	14184.68
Supplies, Insurance, Misc.	13480.69	48937.03	40214.61
Maintenance	409.10	16218.13	13628.24
Depreciation	18300.00	222400.00	216700.00
<b>SUBTOTAL PRODUCTION</b>	<b>373279.10</b>	<b>4016861.16</b>	<b>3384279.63</b>
Distribution -			
Labor	17172.98	190768.01	218475.37
Supplies, Insurance, Misc.	16309.22	82246.67	126469.83
Maintenance	2576.74	57463.48	61346.41
Depreciation	29900.00	354600.00	305800.00
Truck Expense	544.64	8088.49	5436.88
<b>SUBTOTAL DISTRIBUTION</b>	<b>66503.58</b>	<b>693166.65</b>	<b>717528.49</b>
Administration & General -			
Interest Expense	0.00	0.00	0.00
Labor	22719.05	244826.60	219767.92
Payroll Tax & Employee Benefits	18847.83	240971.98	203900.71
Supplies, Insurance, Misc.	17372.57	240462.58	191768.94
Donated Electricity	5550.00	61800.00	63250.00
Uncollectible Accounts	0.00	0.00	0.00
Depreciation	0.00	0.00	0.00
<b>SUBTOTAL ADMIN. &amp; GENERAL</b>	<b>64489.45</b>	<b>788061.16</b>	<b>678687.57</b>
Overhead transferred Out	1208.45	14465.29	10886.96
	63281.00	773595.87	667800.61
<b>TOTAL OPERATING EXPENSES</b>	<b>503063.68</b>	<b>5483623.68</b>	<b>4769608.73</b>
Net Profit (loss) from Operation	8521.53	8407.65	394638.90
Other Income, Including Interest	1183.52	11068.63	20322.30
<b>NET PROFIT (LOSS)</b>	<b>9705.05</b>	<b>19476.28</b>	<b>414961.20</b>

STORY CITY MUNICIPAL ELECTRIC UTILITY						
KW & kWh SUMMARY						
FOR THE 11TH MONTH PERIOD ENDING NOVEMBER 2021						
	2021	2020		2021	2020	
	Current	Current		Year to Date	Year to Date	
	Month	Month				
<b>Operating Revenue:</b>						
Residential	1288277.00	1147532		15928075	15117332	
Commercial	351830.00	320157		4081216	3974981	
Large Power - KW	7953.56	7892		85097	83061	
Large Power - kWh	3479700.00	3080540		35043147	33678100	
Municipal - KW	334.70	309		3216	3231	
Municipal - kWh	135987.00	129814		1405771	1400706	
<b>SUBTOTAL</b>	<b>5264082.26</b>	<b>4686244.26</b>		<b>56546522.74</b>	<b>54257411.00</b>	
<b>TOTAL KW</b>	<b>8288.260</b>	<b>8201.260</b>		<b>88313.736</b>	<b>86292.000</b>	
<b>TOTAL kWh</b>	<b>5255794</b>	<b>4678043</b>		<b>56458209</b>	<b>54171119</b>	

CLERK'S REPORT FOR THE MONTH OF NOVEMBER, 2021										
Funds	Beginning Balance	Interest	Other	Total	Disburst.	Balance	Outstanding Checks/Depts.	Bank Balance		
Reliance State Bank-General Fund-Checking	169,789.89		539,418.39	709,208.28	643,416.54	65,791.74	25,666.14	91,457.88		
Reliance State Bank-Cons. Deposit-Savings	11,138.85	4.95	380.00	11,523.80	960.00	10,563.80	0.00	10,563.80		
Reliance State Bank-Capital Improvement-Savings	2,173,164.60	952.62	40,000.00	2,214,117.22	0.00	2,214,117.22	(40,000.00)	2,174,117.22		
Reliance State Bank-Project Share-Savings	2,457.70	1.63	40,025.00	42,484.33	0.00	42,484.33	0.00	42,484.33		
Reliance State Bank-Alternate Energy-Savings	6,955.13	3.05	14.00	6,972.18	0.00	6,972.18	0.00	6,972.18		
Outstanding Checks/Deposits										
6885	\$0.90		17790	\$44.79						
6886	\$14.53		17791	\$66.40						
6956	\$0.77		17792	\$46.22						
7238	\$3.52		17793	\$26.40						
7261	\$54.70		17794	\$964.46						
7561	\$3.79		17795	\$297.67						
7612	\$5.60		17796	\$1,176.00						
7747	\$8.29		17797	\$314.31						
8077	\$33.17		17806	\$1,981.98						
8155	\$13.94		17807	\$2,025.81						
9057	\$14.23		17808	\$2,211.42						
9200	\$5.59		17809	\$1,981.98						
9261	\$1.68		17810	\$1,981.98						
9575	\$2.34		17811	\$2,025.81						
9832	\$35.84		17812	\$2,211.42						
17540	\$150.00		17813	\$2,103.02						
17696	\$54.61		DFT977	\$398.19						
17697	\$33.57		DEP12353	\$ (297.78)						
17744	\$9.84									
17745	\$46.24									
17760	\$2,334.03									
17767	\$75.00									
17768	\$503.75									
17782	\$920.00									
17788	\$134.80									
17789	\$1,625.33									
								<b>TOTAL IN CAPITAL IMPROVEMENT FUND</b>	<b>2,574,117.22</b>	
								<b>GENERAL FUND TOTAL</b>	<b>400,000.00</b>	
								<b>491457.88</b>		
								<b>531457.88</b>	<b>CURRENT BANK BALANCE</b>	
								<b>(40000.00)</b>	<b>AMOUNT OFF</b>	

# Story City Economic Development Corporation AGENDA

November 18, 2021

Tyler Frederiksen-President	John Gookin	
Adam Wilkinson-VP	Nick Hermanson	Mark Jackson, City
Erik Oleson-Treasurer	Erika Lekwa	Connie Phillips, City
Nicole Engelhardt-Secretary	Brad Eslick	Shanon McKinley, GCC
Nikki- Fisher Ames Chamber	Steve Frey	Rick Schreier, GCC EV Chair

- A. Call to order 7:32 am via Zoom
- B. Minutes and Treasurer's Report Minutes approved by Erik, 2nd by Adam. Treasurers approved by Nicole 2nd by John
- C. Agenda Items
  1. Nikki Fischer-Ames EDC (Retraining initiative) Story County Jobs  
Just started a 3 year program with DMACC open to Story County residents
  2. Partnerships update Not quite where we want to be. Please reach out to your contacts
  3. Fareway update Tyler reached out to Kobe and got him info, said it looks good. Kobe will get his people together and maybe be in town next week to look at site options
  4. Land purchase update moving forward
  5. Trivia night: January 29th 2022 - Randall Gym - Trophy Husband Trivia - PJ theme

6. Annual Dinner -Feb 3rd with GCC will do a Macaroni Cook off as  
BAH

**Next meeting is Thursday, December 15 with GCC Board at 7:30am**

Old Grocery Store location is under contract, hoping to close by end of the year.

Dose started with Story Const. Bid was too High Brett is now doing it himself. Hoping to be operational by end of the year

Dec 7th Connective Group - all invited

BAH Dec 8th @ Norsemen Realty

Adjourn on Zoom 8:01am